



# START HERE!

## READ ME FIRST

Don't be a hero and muscle through this without first reading these fitting instructions! Improper installation of this gear may void certain aspects of your warranty.

Before you begin, take a moment and open all your Front Runner rack kit boxes and gather the assembly instructions for the various components.

A complete kit will contain:

1. A Front Runner Mounting System specific to your vehicle
2. A Front Runner Rack Tray or Load Bar Slats

This document will guide you through the assembly of the mounting system and assist you in fitting the roof rack tray or load bars to your specific vehicle.

Please refer to the next page for a list of all the components, quantities and tools required.

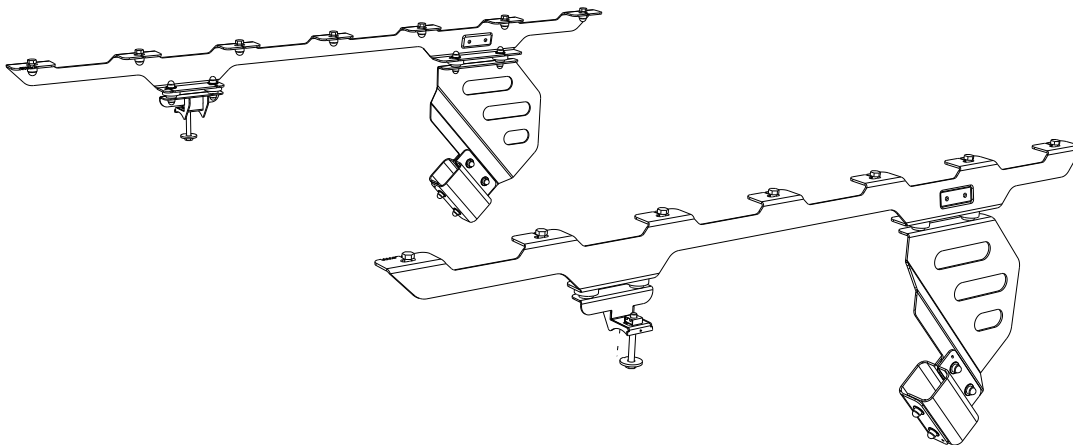

### IMPORTANT WARNING!

FRONT RUNNER CAN NOT RECOMMEND A MAXIMUM LOAD CARRYING CAPACITY. PLEASE REFER TO YOUR VEHICLE MANUFACTURER'S RECOMMENDATIONS. IT IS CRITICAL THAT ALL FRONT RUNNER PRODUCTS BE PROPERLY AND SECURELY ASSEMBLED AND ATTACHED TO YOUR VEHICLE. IMPROPER ATTACHMENT COULD RESULT IN AN AUTOMOBILE ACCIDENT, AND COULD CAUSE SERIOUS BODILY INJURY OR DEATH. YOU ARE RESPONSIBLE FOR ASSEMBLING AND SECURING ALL FRONT RUNNER PRODUCTS TO YOUR VEHICLE. CHECKING THE ATTACHMENTS PRIOR TO USE, AND PERIODICALLY INSPECTING THE PRODUCTS FOR ADJUSTMENT, WEAR AND DAMAGE. THEREFORE YOU MUST READ AND UNDERSTAND ALL OF THE INSTRUCTIONS AND PRECAUTIONS SUPPLIED WITH YOUR FRONT RUNNER PRODUCT PRIOR TO INSTALLATION OR USE. IF YOU DO NOT UNDERSTAND ALL OF THE INSTRUCTIONS AND CAUTIONS, OR IF YOU HAVE NO MECHANICAL EXPERIENCE AND ARE NOT THOROUGHLY FAMILIAR WITH THE INSTALLATION PROCEDURES, YOU SHOULD HAVE THE PRODUCT INSTALLED BY A PROFESSIONAL INSTALLER OR OTHER QUALIFIED PERSONNEL.

# 1

## GET ORGANIZED

FAJK007

### IN THE BOX

1	2 X	Rear Support Bracket - 1LH + 1RH
2	2 X	Middle Support Bracket - 1LH + 1RH
3	2 X	Outer Roll Bar Clamp
4	2 X	Inner Roll Bar Clamp
5	20 X	M6 Nut Cap
6	16 X	M6 x 30 Hex Bolt
7	20 X	M6 x 19 x 1SS Flat Washer
8	16 X	Aluminum Spacer
9	16 X	Foam Seal Washer
10	8 X	M6 x 20 Hex Bolt
11	20 X	M6 Nyloc Nut
12	8 X	M6 x 12 x 1SS Flat Washer
13	2 X	M8 Cage Nut
14	2 X	M8 Large Washer
15	2 X	M8 x 75 Hex Bolt
16	8 X	Sealing Plug Assembly

### TOOLS NEEDED



FIGURE 1.1

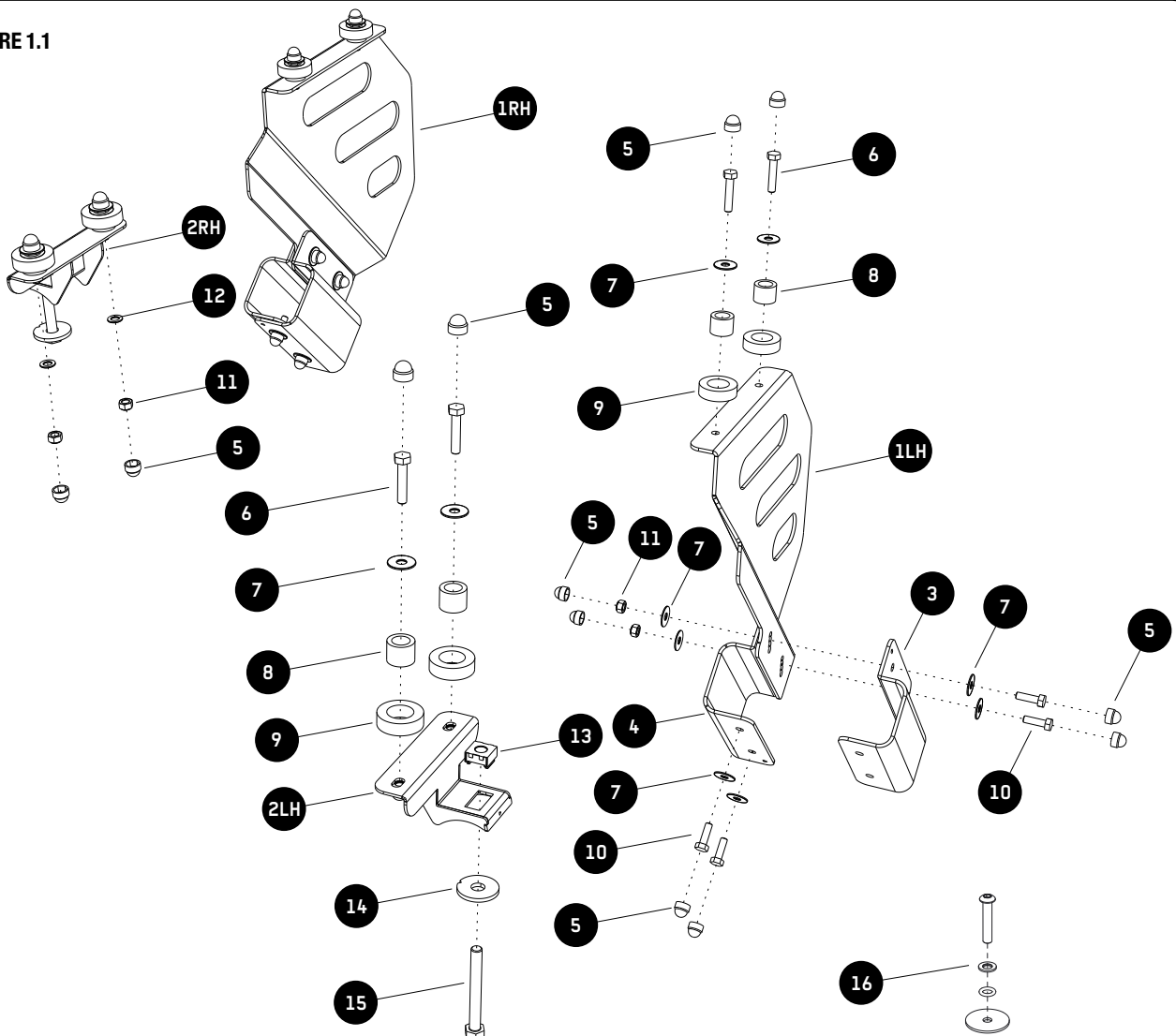

# 1

## GET ORGANIZED

FAJK006

### IN THE BOX

16	14 X	M8 X 16 Hex Bolt
17	2 X	Foot Rail - 1LH + 1RH
18	14 X	M8 x 16 x 1.6SS Flat Washer
19	14 X	M8 Nyloc Nut
20	14 X	M8 Nut Cap

FIGURE 1.2

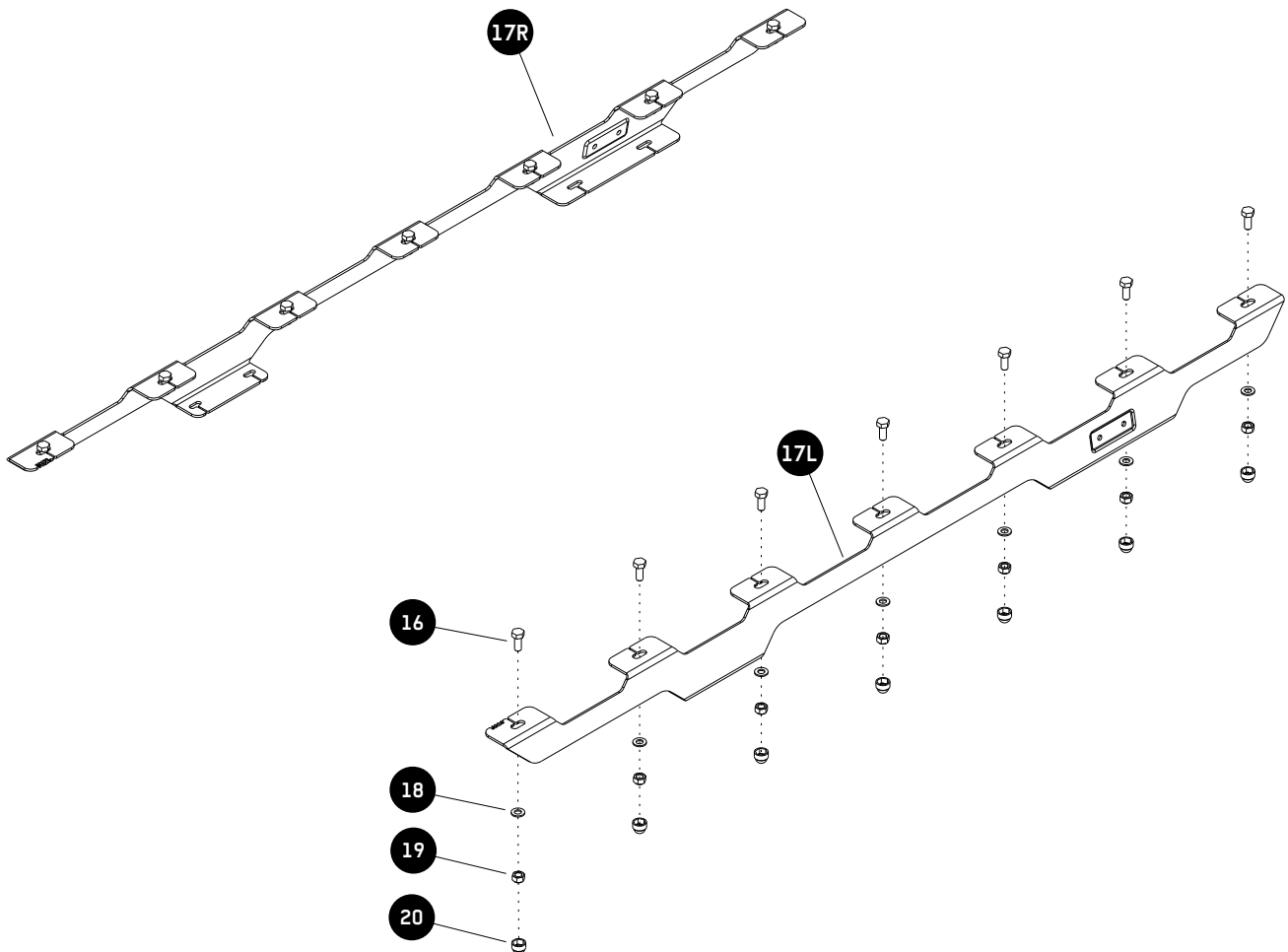

**2**

**PREP FOR INSTALLATION OF INNER BRACKETS (FAJK002)**

2.1



Loosen the velcro, unzip and remove the padding covering the roll bars.

Remove the wiring harness and plastic clip from the roll bar.

2.2



Locate the two threaded holes on the underside of the roll bar and fasten the two halves of the Roll Bar Clamps (Items 3 & 4) to the roll bar using M6 x 19 x 1SS Flat Washers and M6 x 20 Hex Bolts (Items 7 & 10). Place the Outer Roll Bar Clamp (Item 3) first, followed by the Inner Roll Bar Clamp (Item 4).

2.3



Loosely attach the Rear Support Arms (Item 1) to the outside of the Roll Bar Clamps using M6 x 20 Hex Bolts, M6 x 19 x 1SS Flat Washers and M6 Nyloc Nuts (Items 7, 10 & 11). Make sure the foot faces the inside of the vehicle as shown.

Mark the position of the holes in the foot onto the roof.

Once the holes have been marked remove the Rear Support Arms.

Drill 4mm pilot holes on the marks you have made.

### 3

## PREP AND INSTALLATION OF FOOT RAILS (FAJK006)

3.1

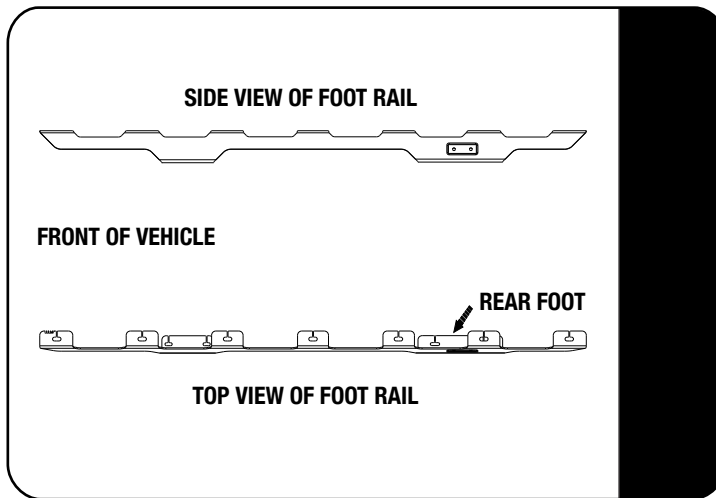

Place the Foot Rail on the roof and align the rear slots of the Foot Rail centre with the holes drilled in 2.3.

3.2

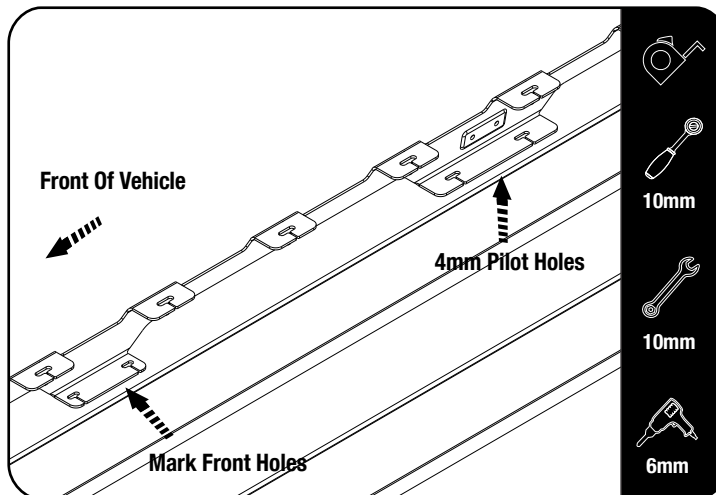

Align the Foot Rail with the rib on the roof so that it runs parallel with the rib before marking the two front holes.

Mark the position of the two front holes of the Foot Rail onto the outside of the roof.

Remove the rail and from the outside, drill 4mm pilot holes on the marks just made.

Do this on both sides of the vehicle.

Using the Foot Rail as a template check that all four holes are centered in the slots of the Foot Rail.

3.3

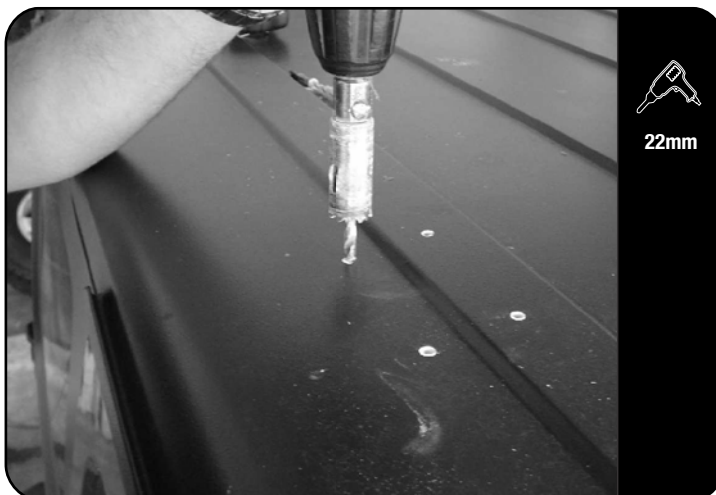

Change the 4mm drill bit to a 22mm hole saw. From the outside of the vehicle, drill all the 4mm holes (8 in total) out to 22mm.

Let the drill do the work. You do not want to scratch or damage your vehicle's roof. Have your friend hold the vacuum cleaner underneath where you are drilling to catch all the dust and keep your vehicle clean.

After drilling, clean the area around all the 22mm holes in the roof with a rag and methylated spirits/denatured alcohol.

3.4

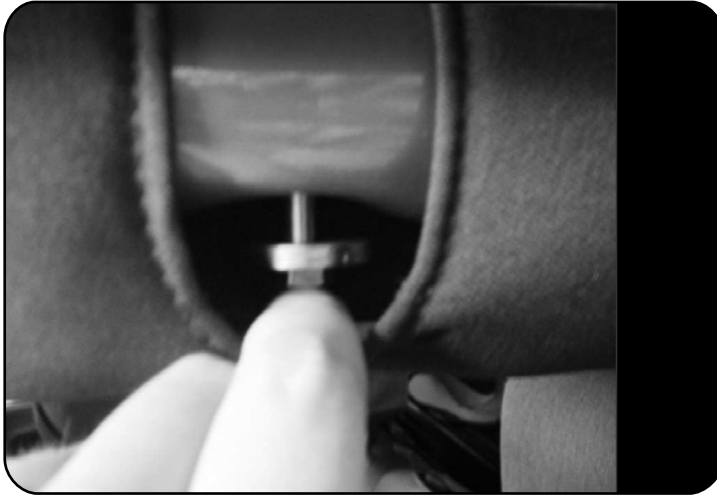

↻ Pull back the padding around the roll bar above the rear seats and insert an M8 x 75 Hex Bolt and M8 Large Washer (Items 14 & 15 from FAJK007 box) through the hole as shown.

3.5

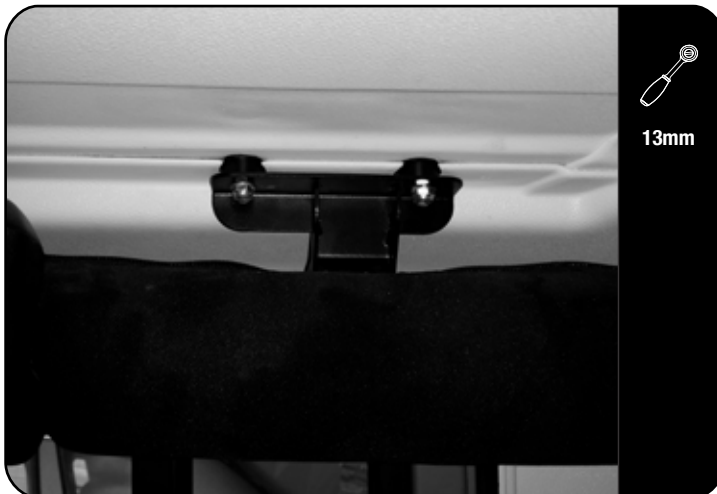

↻ From the inside of the vehicle, in the same position as where you just inserted the bolt in 3.4, push the Middle Support Bracket (Item 2LH & 2RH) through the hole in the roll bar padding and loosely fasten it to the roll bar.

⚠ Please note that there is a left hand and right hand bracket. The arrow on the bracket must point to the rear of the vehicle.

3.6



↻ Refit and fasten the Rear Support Arms as in 2.3

⚠ **NOTE:** Use the worm slots to adjust the height of the rear support brackets. This will be important to create a weatherproof Seal.

3.4

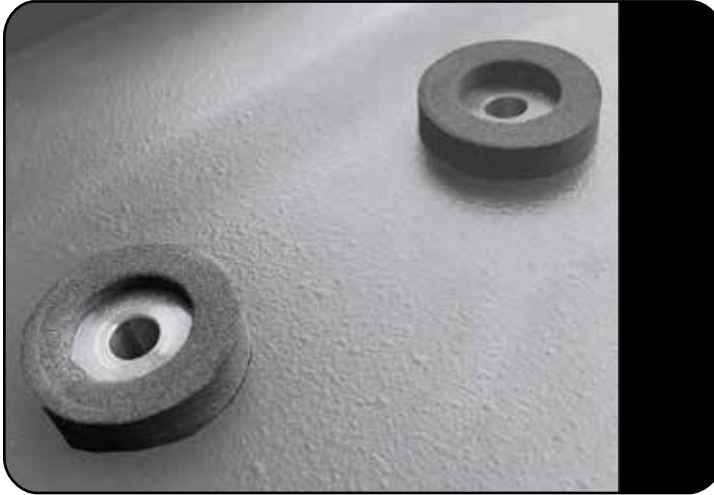

Clean the area around all the 22mm holes drilled in the roof with a rag and methylated spirits/denatured alcohol.

Insert the Aluminum Spacers (Item 8) into the Foam Washer (Item 9). Remove the paper backing from the Foam washer to expose the adhesive.

Insert the washer/spacer assembly, adhesive side down, into the 22mm holes so that the spacer comes to rest on the Rear Support Brackets underneath.

Firmly press the foam washer all the way around securing it to the roof.

3.5

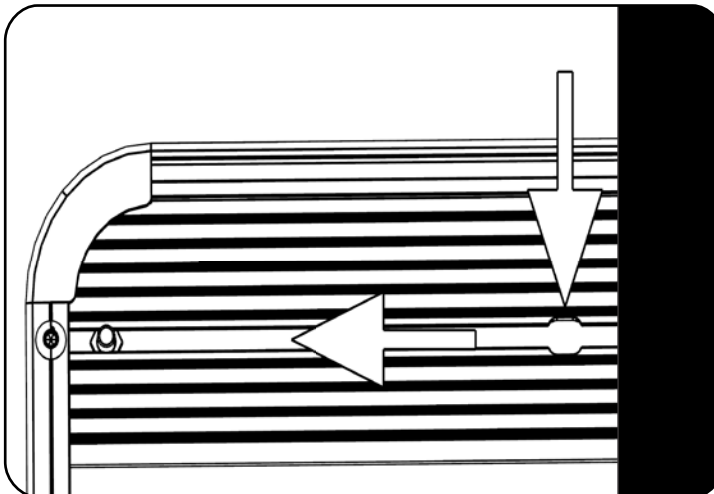

If not already assembled, assemble your Tray as per the Universal Tray Assembly Instructions (Document RRSUNI)



**NOTE:** Before fitting the Wind Deflector, insert two M8 x 16 Hex Bolts (Item 16 from FAJK008) or (Item 1 from FAJK007) into the first slat (Combined Slat), using the Machined slots. Slide a bolt to each of the outer corners.

3.6

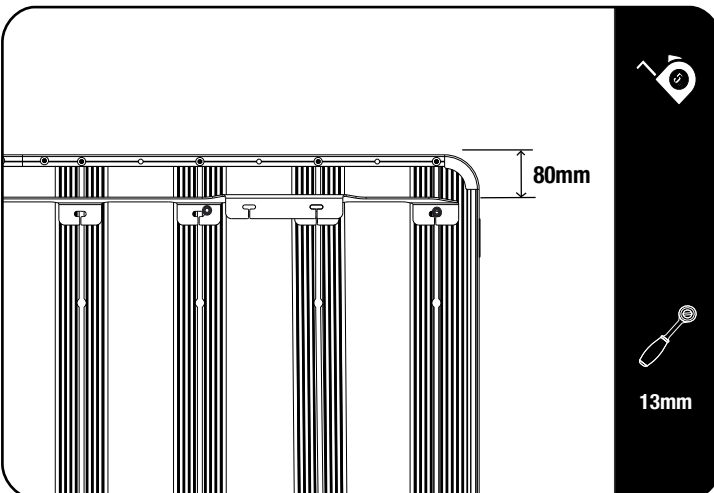

After fitting the wind deflectors, the tray should still be upside down, loosely mount the Foot Rails (Item 17L & 17R from FAJK008 box) to the Tray using M8 x 16 Hex Bolts, M8 X 16 X 1.6SS Flat Washers and M8 Nyloc Nuts (Items 16, 18 & 19). As before use the machined slots to insert the hex bolts into the Slats. The Foot Rail should be mounted at the opposite end of the Tray to the wind deflector.

The rear of the Foot Rail must mount onto the very last Slat (Combined Slat) and approximately 80mm in from the outer edge of the side of the Tray. Do not tighten the bolts yet.

**6****MOUNT YOUR TRAY**

6.1

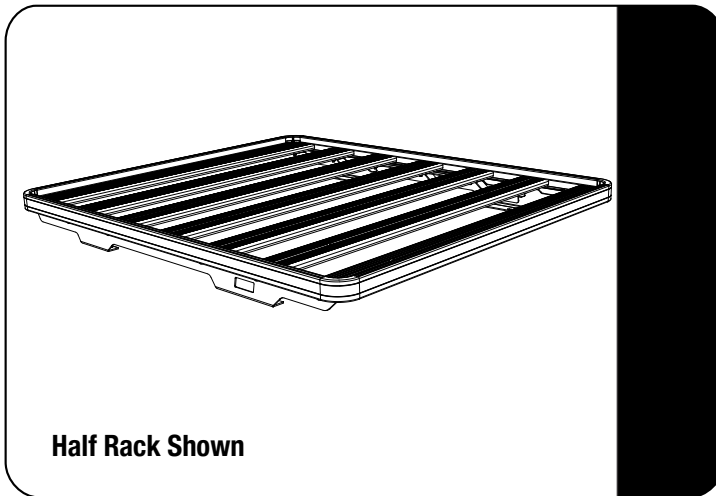

With the help of a friend, flip the Tray end over end so that it is in the upright position. (The Tray is flipped end over end so that bolts and brackets do not slide left and right).

With one of you on either side of the Tray, lift the Tray and walk it into position above the vehicle, approaching from either the front or the rear of the vehicle.

6.2

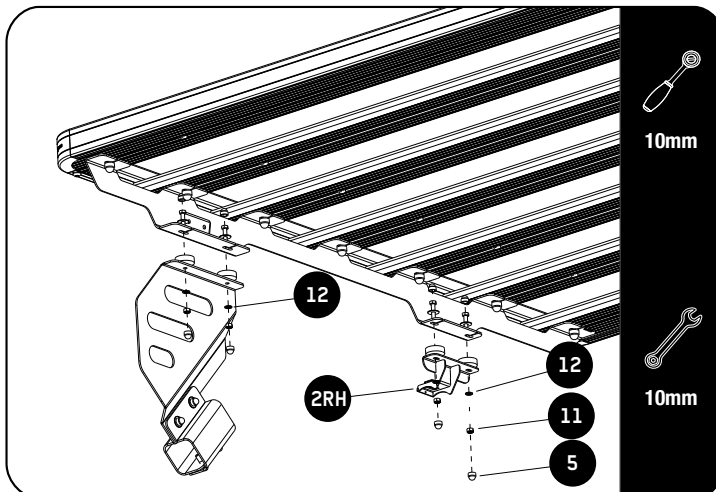

The Foot Rail should still be loose enough to move. Line the brackets up with the holes on the roof and fasten them into position using M6 x 30 Hex Bolts, M6 x 19 x 1SS Flat Washers, M6 x 12 x 1SS Flat Washers and M6 Nyloc Nuts (Items 6, 7, 11 & 12). Centre the tray from left to right. Use a tape measure to double check. Once you are happy that the Tray is in the correct position, fasten all the nuts and bolts, both inside and outside of the vehicle on all brackets that were installed.

Place M6 Nut Caps (Item 5) over all the exposed bolts and close up all the roll bar padding.

**5****REMOVING YOUR RACK**

5.3

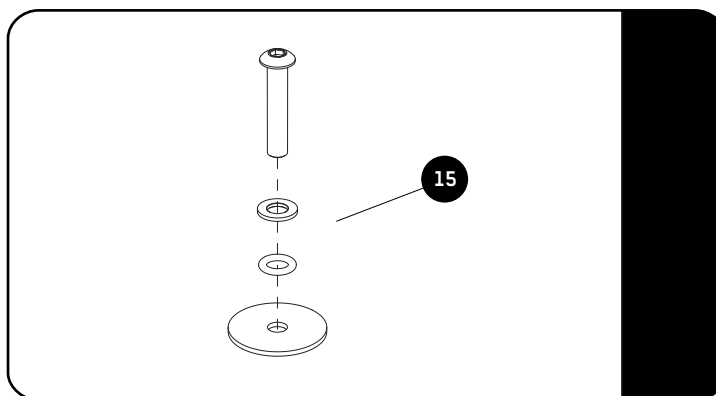

Should you wish to remove your rack, you will need to plug the holes you drilled in the roof (Step 3.4), using the supplied Sealing Plug Assemblies.

Remove the Tray, Front Uprights and the Foot Rail, by reversing the installation procedure. Leave the Foam Washer and the Aluminum Spacers in place. Screw in the Sealing Plugs reusing the M6 Nyloc Nuts and Washers that held the Foot Rail in position.



8

## TAKE A TRIP

8.1 After your first adventure, check that all nuts, bolts, screws and fittings are tight. Re-tighten where needed. You'll find a small amount of settling has happened.

Go on many more adventures, periodically checking all nuts, bolts, screws and fittings.



Front Runner can not recommend a maximum load carrying capacity. Please refer to your vehicle manufacturer's recommendations

9

## COMPLETION

9.1

Congratulations! You did it. Take a step back and admire your work!



10





## INSTALL OTHER VEHICLE AND RACK ACCESSORIES

Now's the time to visit your favorite Front Runner Dealer in person or online.

### IMPORTANT!

FRONT RUNNER RACK KITS OFTEN HAVE A HIGHER LOAD RATING THAN THE VEHICLES THEY ARE MOUNTED TO. PLEASE REFER TO YOUR SPECIFIC VEHICLE MANUFACTURER FOR A RECOMMENDED ROOF RATING. FRONT RUNNER CANNOT BE RESPONSIBLE FOR IMPROPER LOADING BEYOND THE VEHICLE MANUFACTURER'S STATED LOAD CAPACITY.

Be sure to tag us. We love to see our gear in action! #FrontRunnerOutfitters #BornToRoam

Share your adventures on:    

# FRONT RUNNER

## JEEP WRANGLER JK 2 DOOR & 4 DOOR (2007 - 2018) FRONT PILLAR BRACKETS

ENG

FAJK009

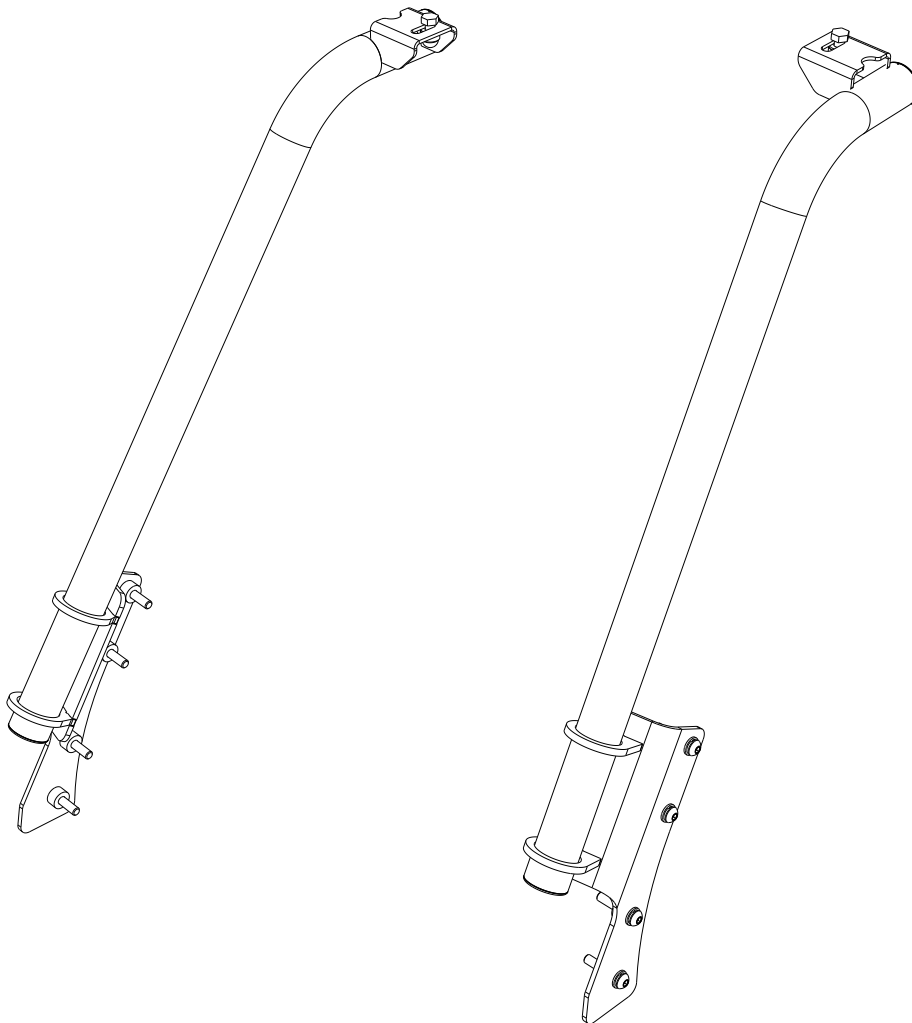

### READ ME !

Thank you for purchasing Front Runner Jeep Wrangler JK Front Pillar Brackets.

Before you start, take a moment to familiarize yourself with the Fitting Instructions and the components received.

Refer to Page 2 for a list of all the components, quantities and tools required.

### IMPORTANT WARNING!

IT IS CRITICAL THAT ALL FRONT RUNNER PRODUCTS BE PROPERLY AND SECURELY ASSEMBLED AND ATTACHED TO YOUR VEHICLE. IMPROPER ATTACHMENT COULD RESULT IN AN AUTOMOBILE ACCIDENT, AND COULD CAUSE SERIOUS BODILY INJURY OR DEATH. YOU ARE RESPONSIBLE FOR ASSEMBLING AND SECURING ALL FRONT RUNNER PRODUCTS TO YOUR VEHICLE, CHECKING THE ATTACHMENTS PRIOR TO USE, AND PERIODICALLY INSPECTING THE PRODUCTS FOR ADJUSTMENT, WEAR AND DAMAGE. THEREFORE, YOU MUST READ AND UNDERSTAND ALL OF THE INSTRUCTIONS AND PRECAUTIONS SUPPLIED WITH YOUR FRONT RUNNER PRODUCT PRIOR TO INSTALLATION OR USE. IF YOU DO NOT UNDERSTAND ALL OF THE INSTRUCTIONS AND CAUTIONS, OR IF YOU HAVE NO MECHANICAL EXPERIENCE AND ARE NOT THOROUGHLY FAMILIAR WITH THE INSTALLATION PROCEDURES, YOU SHOULD HAVE THE PRODUCT INSTALLED BY A PROFESSIONAL INSTALLER OR OTHER QUALIFIED PERSONNEL.

**NOTE:** Front Runner will not be responsible for any damage caused by the failure to install the product according to these instructions.

Please call us if you have any questions about the installation of this product.

**1**

**GET ORGANIZED**

**IN THE BOX**

1	2 X	Front Pillar Bracket - 1LH + 1RH
2	2 X	M8 x 20 Hex Bolt
3	10 X	M8 x 16 x 1.6SS Flat Washer
4	2 X	M8 Nyloc Nut
5	2 X	M8 Nut Cap
6	8 X	M8 x 45 Button Head Bolt
7	8 X	M8 Spring Washer
8	8 X	Spacer 8.2 x 18 x 10

**TOOLS NEEDED**

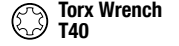

**FIGURE 1.1**

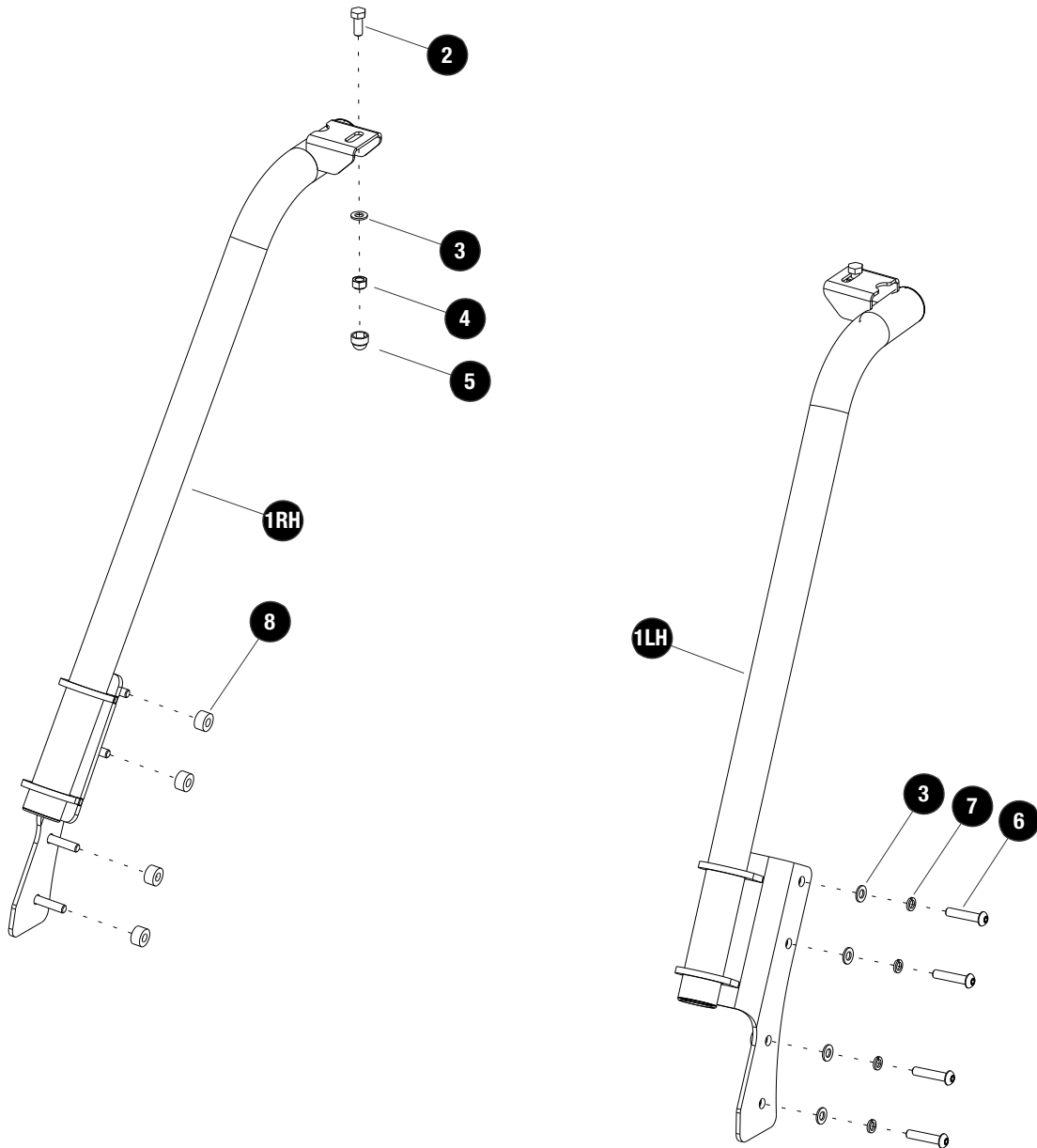

## 2

## FIT AND SECURE

2.1

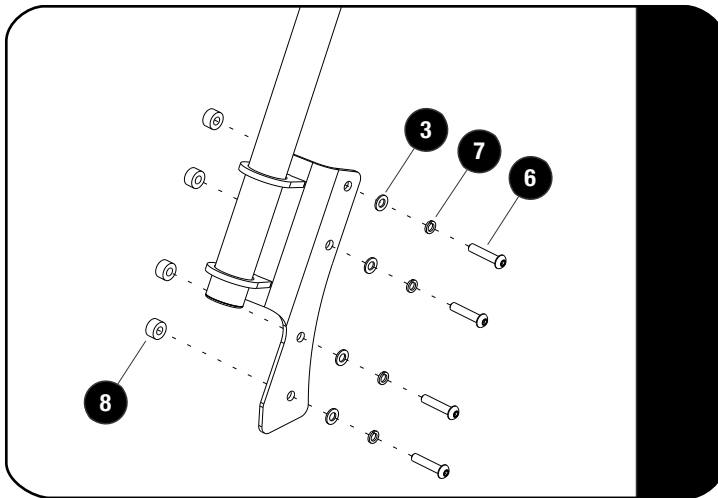

Align the holes in the Front Pillar Bracket mount plate with the holes on the vehicle. Loosely assemble the Pillar Bracket to the vehicle using M8 x 45 Button Head Bolts, M8 SS Spring Washers, M8 x 16 x 1.6SS Flat Washers and the spacers (Items 3, 6, 7 & 8) as shown.

Make sure the Front Pillar Brackets are straight, using the door shut line as a guide before fully tightening the four M8 Button Heads Bolts.

Do this on both left and right side of the vehicle.

2.2

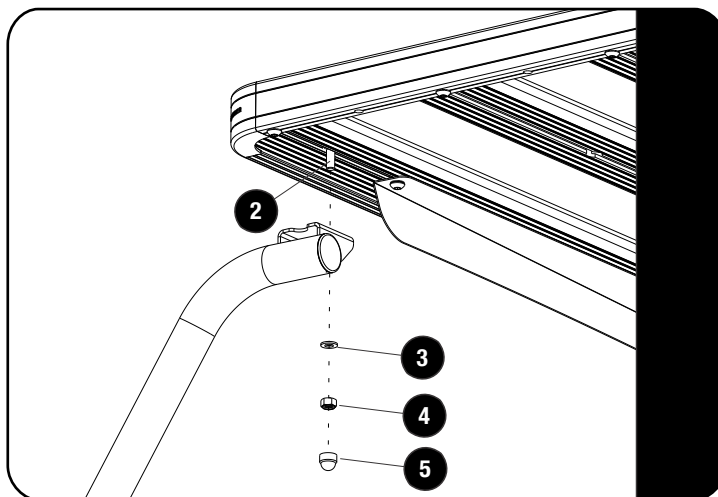

Fit your Roof Rack to the Front Support Arms using M8 x 20 Hex Bolts, M8 x 16 x 1.6SS Flat Washers and M8 Nyloc Nuts (Items 2, 3 & 4) as shown.

Center the rack and tighten fully. Use M8 Nut Caps (Item 5) to finish off the nuts.

## 3

## FINISH

Congratulations! You did it. Take a step back and admire your work!

## 4

## INSTALL OTHER VEHICLE AND RACK ACCESSORIES

Now's the time to visit your favorite Front Runner Dealer in person or online.

Be sure to tag us. We love to see our gear in action! #FrontRunnerOutfitters #BornToRoam

Share your adventures on:





**READ ME !** 

Thank you for purchasing a Front Runner Slimline II Tray.

Before you start, take a moment to familiarize yourself with the Fitting Instructions and the components received.

Refer to Page 2 for a list of all the components, quantities and tools required.

**IMPORTANT WARNING!** 

IT IS CRITICAL THAT ALL FRONT RUNNER PRODUCTS BE PROPERLY AND SECURELY ASSEMBLED AND ATTACHED TO YOUR VEHICLE. IMPROPER ATTACHMENT COULD RESULT IN AN AUTOMOBILE ACCIDENT, AND COULD CAUSE SERIOUS BODILY INJURY OR DEATH. YOU ARE RESPONSIBLE FOR ASSEMBLING AND SECURING ALL FRONT RUNNER PRODUCTS TO YOUR VEHICLE, CHECKING THE ATTACHMENTS PRIOR TO USE, AND PERIODICALLY INSPECTING THE PRODUCTS FOR ADJUSTMENT, WEAR AND DAMAGE. THEREFORE, YOU MUST READ AND UNDERSTAND ALL OF THE INSTRUCTIONS AND PRECAUTIONS SUPPLIED WITH YOUR FRONT RUNNER PRODUCT PRIOR TO INSTALLATION OR USE. IF YOU DO NOT UNDERSTAND ALL OF THE INSTRUCTIONS AND CAUTIONS, OR IF YOU HAVE NO MECHANICAL EXPERIENCE AND ARE NOT THOROUGHLY FAMILIAR WITH THE INSTALLATION PROCEDURES, YOU SHOULD HAVE THE PRODUCT INSTALLED BY A PROFESSIONAL INSTALLER OR OTHER QUALIFIED PERSONNEL.

**NOTE:** Front Runner will not be responsible for any damage caused by the failure to install the product according to these instructions.  
Please call us if you have any questions about the installation of this product.

# 1 GET ORGANIZED

Depending on which size Slimlime II Tray you order, quantities may vary from those pictured.

Here is what you are looking at for RRSUNI:

## IN THE BOX

1	32 X	M8 Nyloc Nut
2	4 X	M8 x45 Button Head Bolt
3	2 X	Thick Joiner Piece
4	2 X	Thin Joiner Piece
5	4 X	Side Profile
6	4 X	Corner
7	2 X	Combined Slat
8	28 X	M8 x 25 Button Head Bolt
9	12 X	Standard Slat
10	4 X	M6 x 10 Button Head Bolt

## TOOLS NEEDED

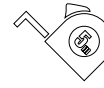
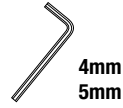
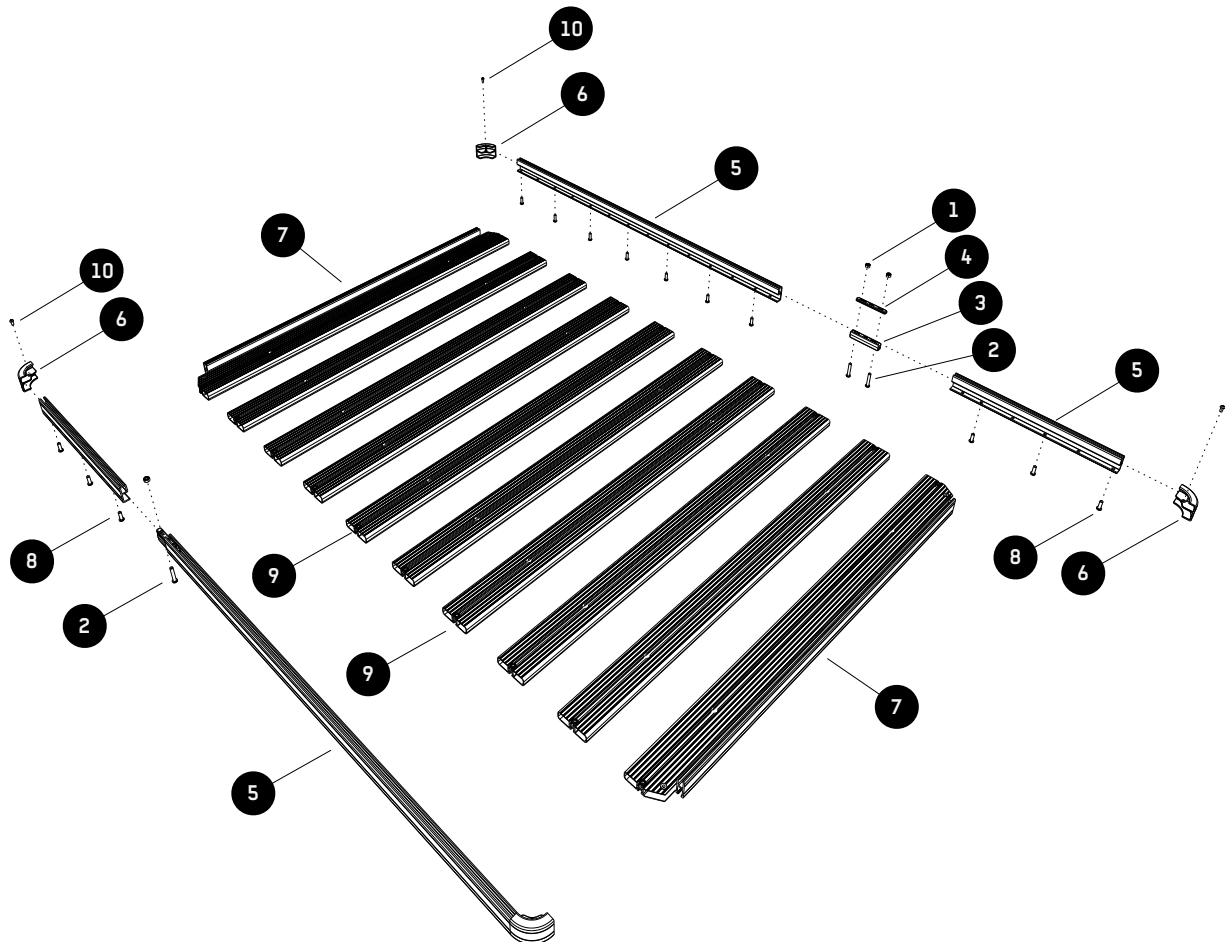

FIGURE 1.1





**NOTE:** Skip this step if your Slimline II Tray is 1560mm or shorter. you will only have two Side Profiles and assembly is not required.

If you have received four lengths of Side Profile (Item 5), you will need to join the pieces together using the Joiners (Items 3 & 4) to form only two lengths by following the easy steps below.

With the exception of the 2772mm long Slimline II Tray, the joints in the Side Profile will be diagonally opposite each other once the Tray is assembled.

2.1

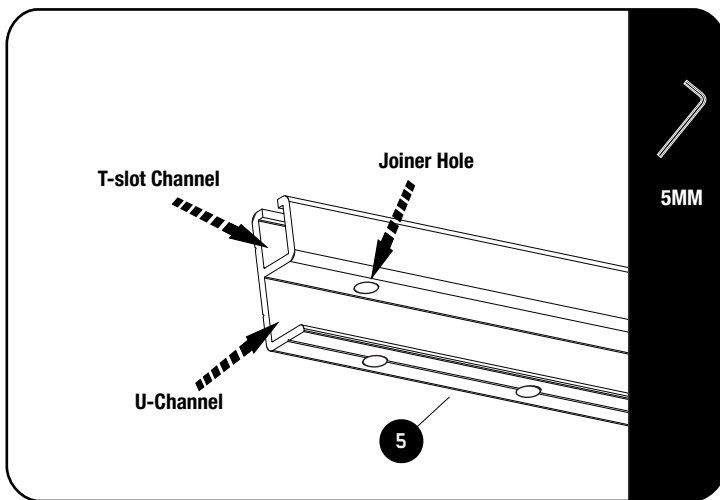

The Side Profiles are supplied in pairs. Take one profile from each pair, one short and one long (Except for the 2772mm long Slimline II rack where the Side Profiles will be equal length. Even though both pairs are the same length it is still important that you take one Side Profile from each pair).

If you look at the Side Profiles you will see that at one end there is a hole that goes through the top and bottom of the "U" Channel.

(Refer to Image 2.1). These are the Joiner Holes that you will be using.

2.2

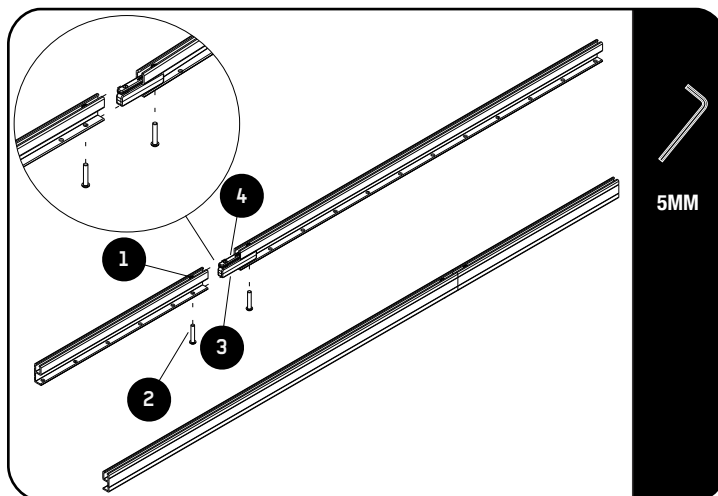

Insert a Thick Joiner (Item 3) into the "U" Channel of the Side Profile lining up the first hole with the hole in the side profile as show in 2.2.

Now grab a Thin Joiner (Item 4) and Nyloc Nut (Item 1). Slide the Joiner into the "T-slot", followed by a Nyloc Nut. The Nyloc Nut should sit on top of the Thin Joiner with the "Dome" of the Nyloc Nut facing up. Line up the outer hole of the Thin Joiner and Nyloc Nut with the Joiner Hole and loosely fasten it all together using a M8 x 45 Button Head Bolt (Item 2) and a 5mm Allen Wrench.

Slide the matching Side Profile over the two Joiner pieces, remembering to insert a Nyloc Nut, and fasten once again using a M8 x 45 Button Head Bolt. Repeat the above steps for the other side.

### 3 RACK ASSEMBLY - COMBINED SLATS AND STANDARD SLATS

3.1

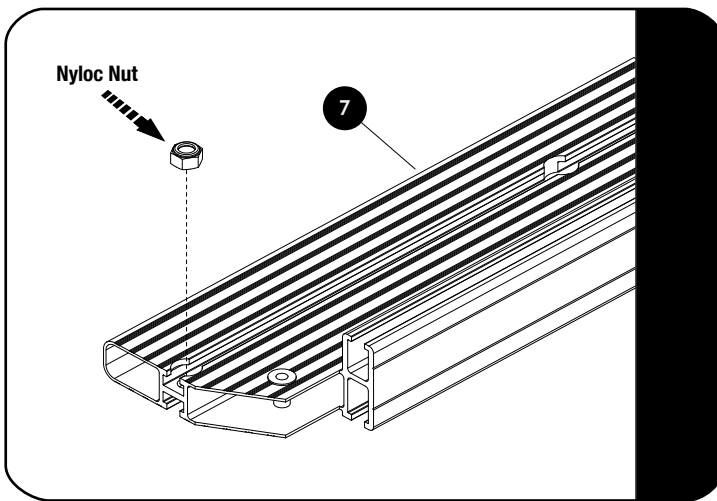

Look at the Combined Slats and Standard Slats (Item 7 & 9) and ensure that there is a Nyloc Nut inserted into each machined end pocket. If the Nyloc Nut has fallen out during shipping, insert it back into the pocket as shown.

3.2

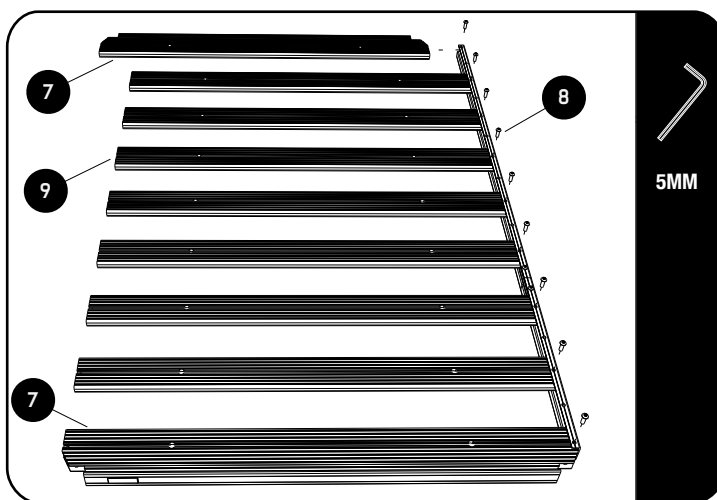

Turn the Combined Slat (Item 7) and the Side Profile Assembly upside down. Ensure that the nut in the Combined Slat is at the bottom. Push the one end of the Combined Slat into the Side Profile assembly and align the holes.

Use a M8 x 25 Button Head (Item 8) and loosely tighten using a 5mm Allen Wrench.

Do the same with the second Combined Slat on the other end of the Side Profile Assembly.

Take a Standard Slat (Item 9) and as with the Combined Slat, slide the one end into the Side Profile Assembly as shown. Ensure that the nut is at the bottom.

Use a M8 x 25 Button Head Bolt (Item 8) and loosely fasten the Standard Slat to the Side Profile using a 5mm Allen Wrench.

Repeat the process for the remaining Standard Slats making sure that there is an open hole in the Side Profile in between each slat.

3.3

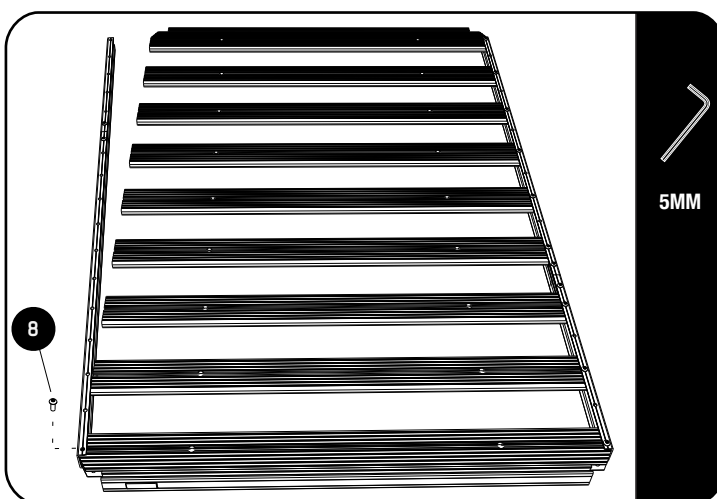

Take the other Side Profile Assembly and starting at the one end push the Side Profile over the ends of the Combined Slat and Standard Slats, aligning the holes and loosely inserting the M8 x 25 Button Heads as you work your way to the Combined Slat at the other end.



3

### RACK ASSEMBLY - STANDARD SLATS

3.4

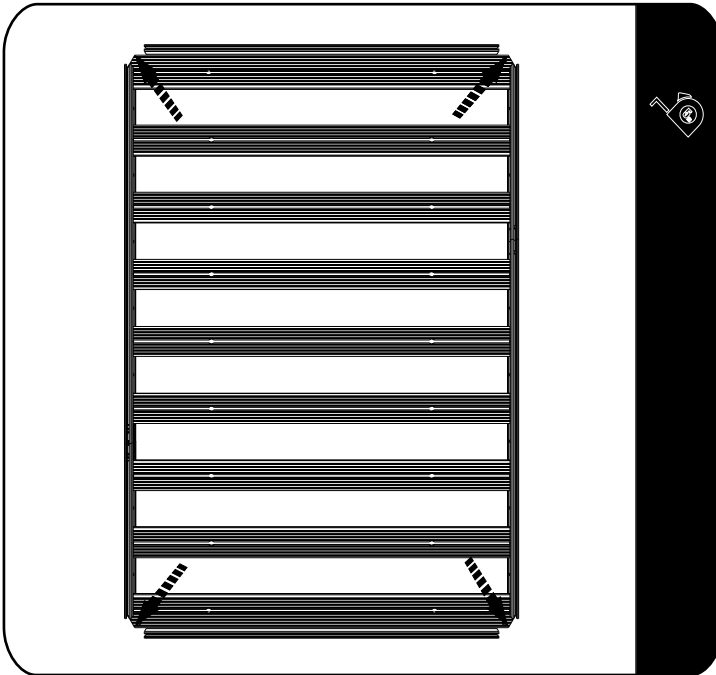

Square the Side Profiles and Slats up before fully tightening all the fasteners.

Using a tape measure, measure from the one corner across to the other corner. Do the same on the opposite corners, if the two measurements are the same the rack will be square.

Fully tighten all the M8 x 25 Button Head Bolts



The recommended torque setting for the M8 Button Head Bolts is 20 Nm or 15 ft lb.

4

### RACK ASSEMBLY- CORNERS

4.1

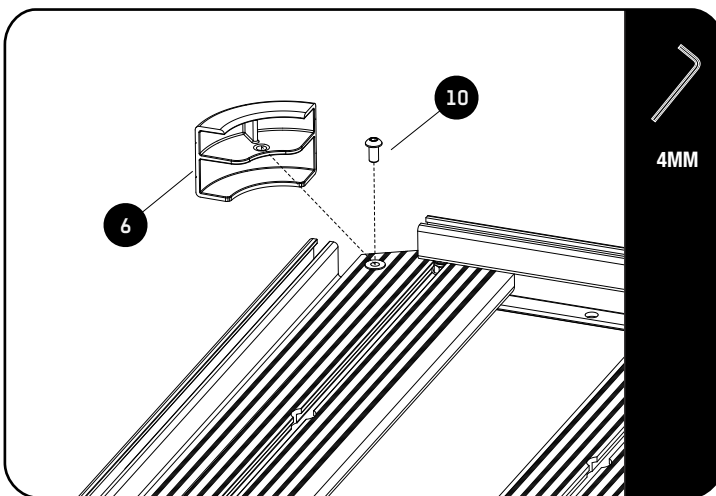

Flip the tray right side up.

Push the Corner into position as shown, aligning the hole in the Corner with the Rivnut already inserted in the Combined Slat. Use a M6 x 12 Button Head Bolt (Item 10) and fasten the Corner in position.

## 5 RACK ASSEMBLY - WIND DEFLECTOR

### IN THE BOX

1	1	Slimline II Tray
2	4	M8 Half Nut
3	2	Wind Deflector (1LH + 1RH)
4	4	Schnorr Washer
5	4	M8 x 12 Button Head Bolt

### TOOLS NEEDED



FIGURE 1.2

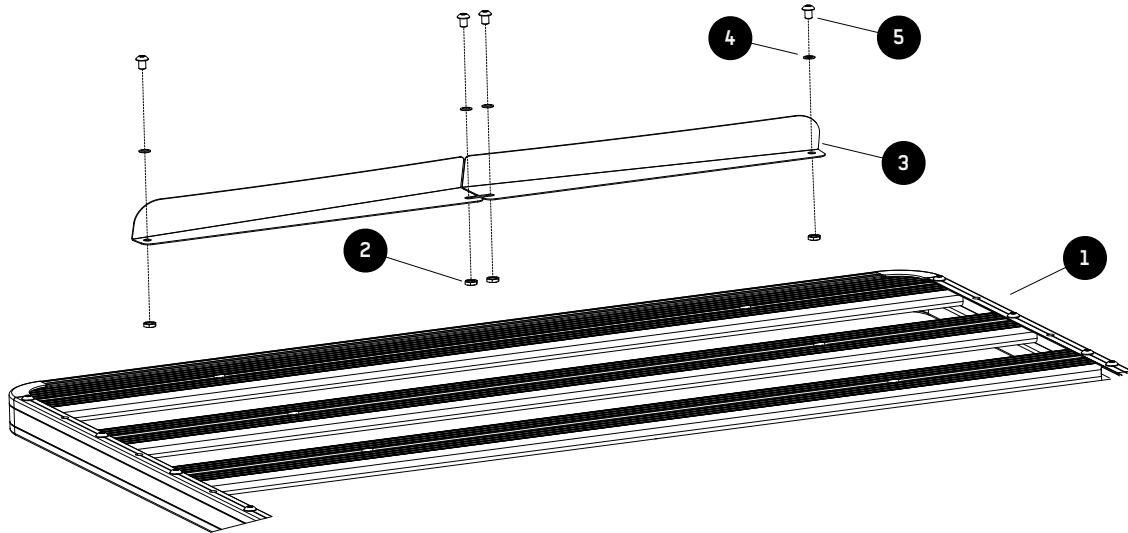

**6****RACK ASSEMBLY - WIND DEFLECTOR**

**NOTE :** The Wind Deflector must be fitted to the underside of the front Combined Slat.

If you are going to put a Leg or Foot on the Combined Slat (Recommended), you will need to slide the M8 Bolt used for attaching these into the Machined Slots before assembling the Wind Deflector.

6.1



Ensure that your Slimline II Tray is upside down. Check by looking at the product sticker. It should be upside down as shown.

6.2

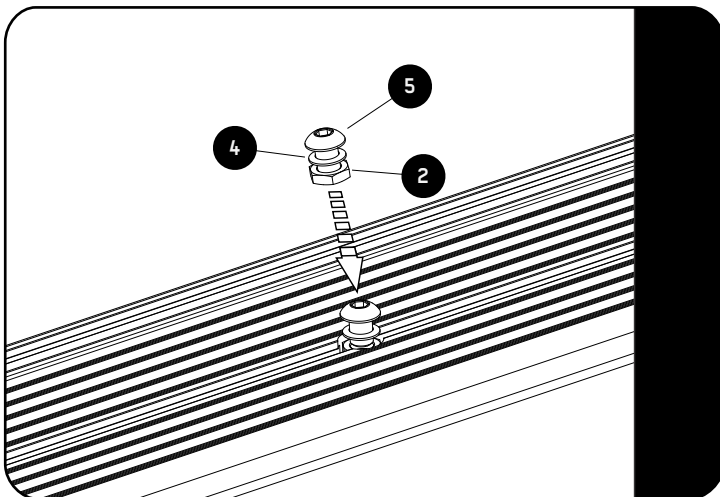

Insert two Button Head Bolts, M8 Half Nuts and Schnorr Washers (Items 2, 4 & 5) assemblies into the Combined Slat as shown. Slide them to the center of the Combined Slat making sure that the Schnorr Washer is above the T-slot Channel.

6.3

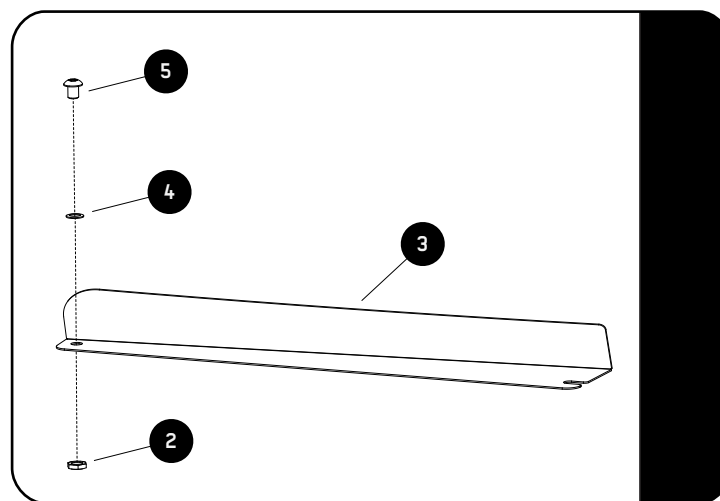

Assemble Items 2, 4 & 5 to both LH & RH Wind Deflectors (Item 3) as shown.

## 6

## RACK ASSEMBLY - WIND DEFLECTOR

6.4

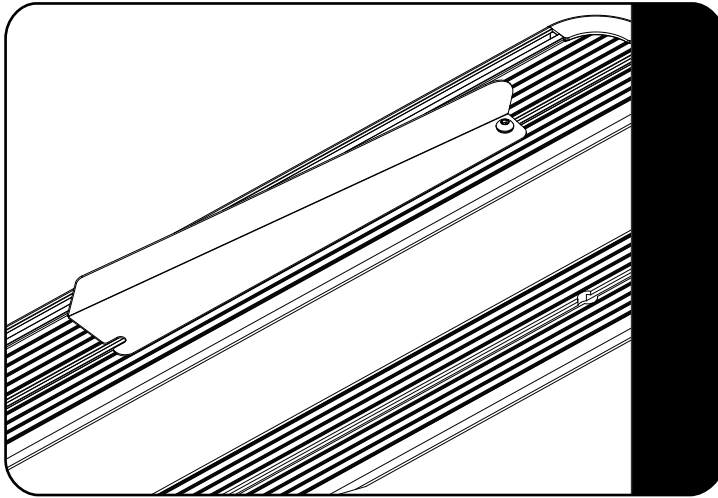

Insert the nut assembled to the Wind Deflector in the Combined Slat T-slot Pocket and slide to the side as shown in Figure 8.4.

Repeat for the other half of the Wind Deflector.

6.5

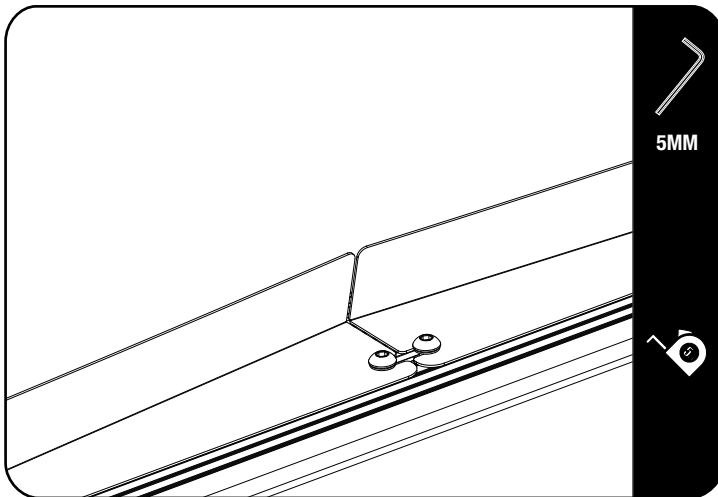

Center the Wind Deflector on the rack and move the bolt assemblies from Figure 8.2 into the slots as shown in Figure 8.5.



**NOTE :** Once the rack is fitted to the vehicle, take it for a test drive. Should there be excessive wind noise try moving the two Wind Deflectors slightly apart, leaving a gap of about 20 - 30mm.



**USEFULL TIP - PRE-LOAD TIE DOWN RINGS**

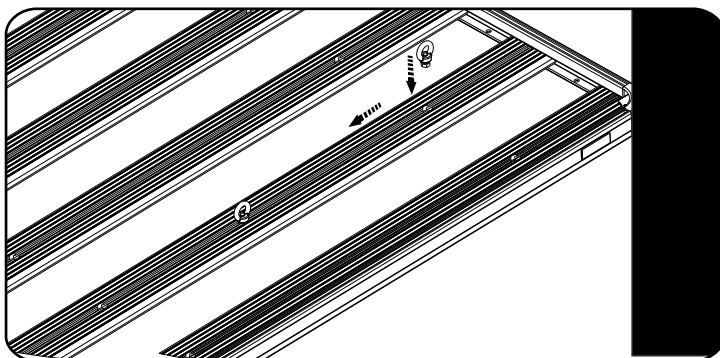

It is usefull to fit Tie-Down Rings (RRAC012) to your Front Runner Rack for future use before you fit any accessories.

Insert the Tie Down Rings into the machined slots and position them in the center of the rack.

7

## CHECK YOUR VEHICLE INSTALLATION GUIDE

7.1

Now that your Slimline II Tray is assembled, get your Rack Kit Installation Guide out and follow the instructions to fit the Slimline II Tray to your specific vehicle.

8

## HOW TO CARE FOR YOUR FRONT RUNNER GEAR

### FRONT RUNNER RACKS AND ACCESSORIES ARE HAPPIEST COVERED IN MUD

But in order to maintain full functionality of the rack slots and any moving parts, you may want to give your gear a bath now and again.

It's easy! Take care of your Front Runner gear the same way you do the exterior of your vehicle:

Rinse with clean water and wipe down with a soft dry cloth. For stubborn spots, use a soft brush and mild soap.

If you really want to baby your gear, feel free to lightly wax the surfaces or use a protective spray with UV inhibitors. Just be sure not to use compound waxes that contain abrasives.

In salty coastal climates, or snowy regions where salt is used to clear roadways, applying a silicone based oil or spray to nuts and bolts will help prevent corrosion.





WHETHER YOU LIKE TO ROLL DIRTY OR CLEAN, YOUR FRONT RUNNER GEAR WILL GIVE YOU MANY YEARS OF SERVICE!

9

## INSTALL OTHER VEHICLE AND RACK ACCESSORIES

Now's the time to visit your favorite Front Runner Dealer in person or online.

Be sure to tag us. We love to see our gear in action! #FrontRunnerOutfitters #BornToRoam

Share your adventures on:    

**BITTE ZUERST LESEN** ⚠

Vielen Dank, dass Du Dich für ein Trägersystem von Front Runner entschieden hast.  
Bevor Du beginnst, nimm Dir einen Moment Zeit und mache Dich mit der Montageanleitung  
und allen Komponenten vertraut.

**WICHTIGER HINWEIS** ⚠

STELLE UNBEDINGT SICHER, DASS ALLE FRONT RUNNER PRODUKTE ORDNUNGSGEMÄß ZUSAMMENGEBAUT UND SICHER AN DEINEM FAHRZEUG BEFESTIGT SIND. EINE UNSACHGEMÄßE INSTALLATION KÖNNTE ZU EINEM UNFALL UND ZU ERNSTHAFTEN FOLGEN UND SCHÄDEN DRITTER FÜHREN, BIS HIN ZU TÖDLICHEN VERLETZUNGEN. DU BIST DAFÜR VERANTWORTLICH, ALLE FRONT RUNNER PRODUKTE ZUSAMMENZUBAUEN UND AN DEINEM FAHRZEUG ZU SICHERN, DIE BEFESTIGUNGEN VOR EINER VERWENDUNG REGELMÄßIG AUF EINSTELLUNG, ABNUTZUNG ODER SCHÄDEN ZU PRÜFEN. LIES DAHER UNBEDINGT VOR DER MONTAGE ODER DER VERWENDUNG ALLE MIT DEINEM FRONT RUNNER PRODUKT GELIEFERTEN ANWEISUNGEN UND HINWEISE. FALLS DU NICHT ALLE ANWEISUNGEN ODER HINWEISE VERSTEHST ODER DU KEINE TECHNISCHE ERFAHRUNG BESITZT UND MIT DEM ZUSAMMENBAUEN NICHT VERTRAUT BIST, SOLLTEST DU DAS PRODUKT VON TECHNISCHEM FACHPERSONAL ODER EINER ANDERWEITIG QUALIFIZIERTEN PERSON VERBAUEN LASSEN.

HINWEIS: Front Runner übernimmt keine Verantwortung oder Haftung für Schäden durch unsachgemäße Montage, die von der Montageanleitung abweicht.  
Solltest Du irgendwelche Fragen zur Installation dieses Produktes haben, kontaktiere uns einfach.

# 1 ERSTE VORBEREITUNGEN

Je nach Größe Deines Slimline II Dachträgers, kann die Anzahl der unten aufgeführten Bestandteile abweichen.

Im folgenden die Bestandteile für das Beispiel dieser Universalmontageanleitung:

INHALT		
1	32 X	M8 Selbstsichernde Mutter
2	4 X	M8 x 45 Rundkopfschraube
3	2 X	Dickes Verbindungsstück
4	2 X	Dünnes Verbindungsstück
5	4 X	Seitenprofil
6	4 X	Eckstück
7	2 X	Kombileiste
8	28 X	M8 x 25 Rundkopfschraube
9	12 X	Querleiste
10	4 X	M6 x 10 Rundkopfschraube

**DU BENÖTIGST**



4 MM  
5 MM

ABBILDUNG 1.1

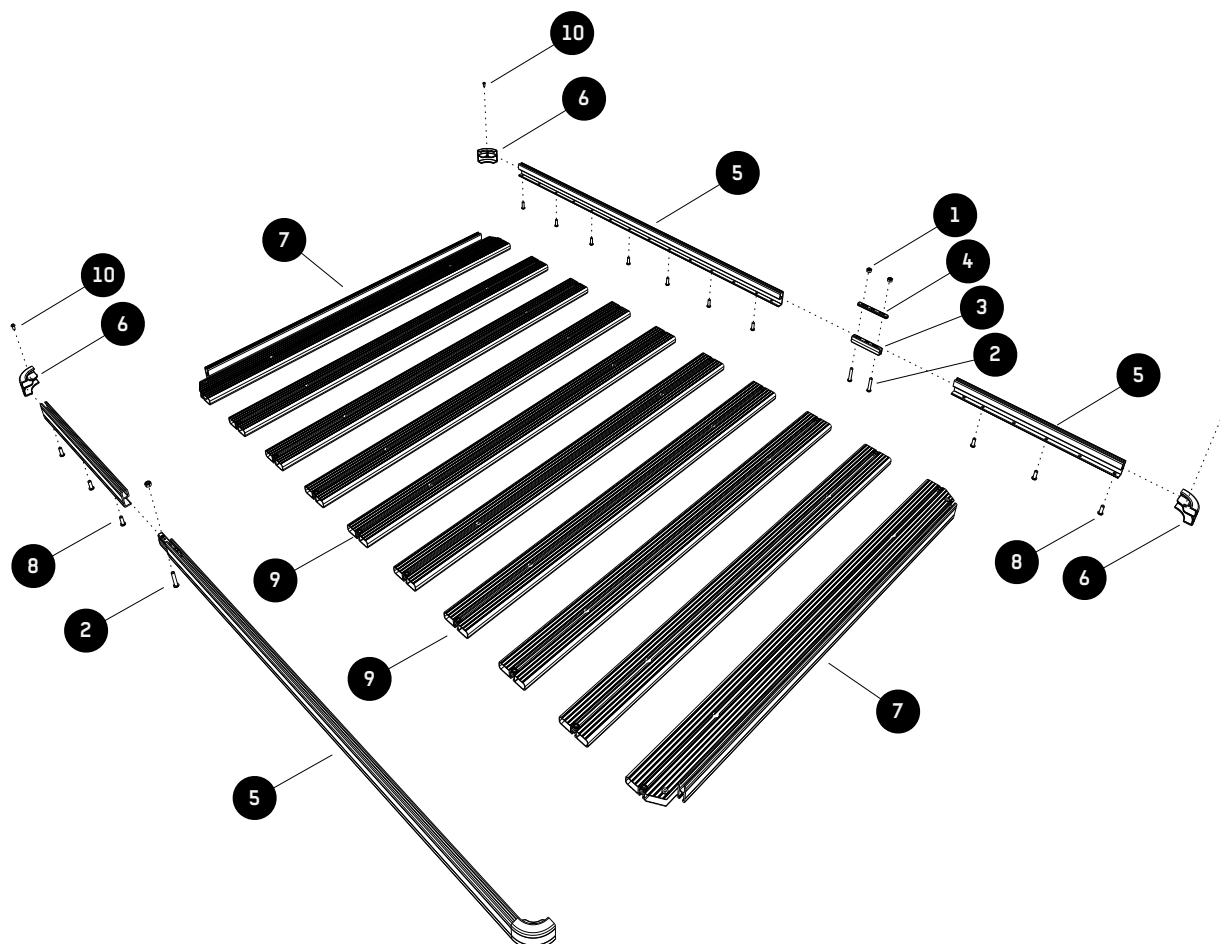

## 2 MONTAGE DER SEITENPROFILE



**HINWEIS:** Überspringe diesen Schritt, wenn Dein Slimline II Dachträger in der Länge 1560 mm oder kürzer ist. In diesem Fall hast Du nur zwei Seitenprofile und es ist kein Zusammenbau erforderlich.

Falls Du vier Längen des Seitenprofils (Teil 5), erhalten hast, musst Du die Teile unter der Verwendung der Verbindungsstücke (Teil 3 & 4) zusammenbauen, sodass Du zwei Längen erhältst. Gehe dafür gemäß der folgenden Schritte vor.

Mit Ausnahme eines 2772 mm langen Slimline II Dachträgers, sind die Verbindungen nach dem Zusammenbau in den Seitenprofilen des Dachträgers einander diagonal gegenüber.

2.1

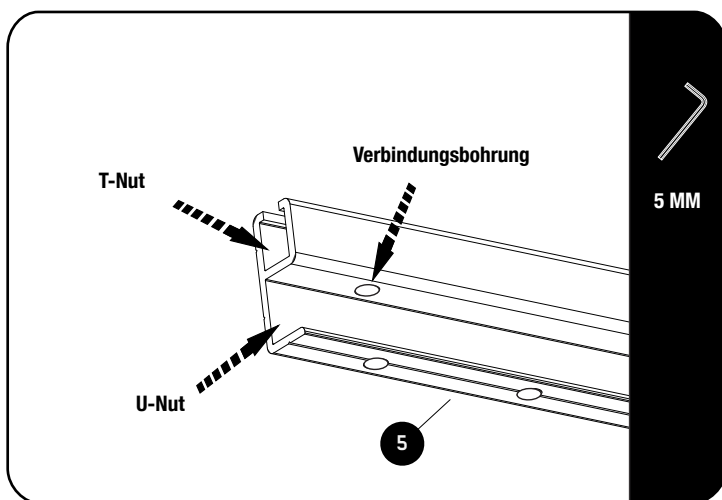

Die Seitenprofile sind paarweise verpackt. Entnimm jeweils ein Seitenprofil von jedem Paar, ein kurzes und ein langes (bei einem 2772 mm langen Slimline II Dachträgers haben die Seitenprofile die gleiche Länge, entnimm auch in diesem Fall jeweils ein Seitenprofil von jedem Paar).

Wenn Du Dir die beiden Seitenprofile ansiehst, wirst Du feststellen, dass eine Bohrung durch das obere und untere Ende des "U"-Nut des Seitenprofils geht (siehe Abb. 2.1).

Dies sind die Verbindungsbohrungen, die Du verwenden wirst.

2.2

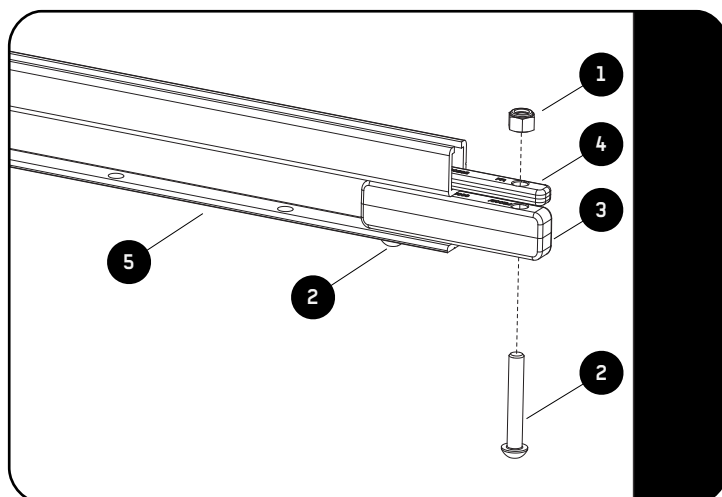

Führe ein dickes Verbindungsstück (Teil 3) in die U-Nut des Seitenprofils und richte die erste Bohrung mit der Verbindungsbohrung aus. Lasse hierbei zwei Bohrungen über der Kante des Seitenprofils frei (Abb. 2.2).

Nimm Dir nun ein dünnes Verbindungsstück (Teil 4) und eine selbstsichernde Mutter (Teil 1). Schiebe das dünne Verbindungsstück in die T-Nut, gefolgt von der selbstsichernden Mutter. Die selbstsichernde Mutter sollte oben auf dem dünnen Verbindungsstück sitzen, wobei die "Kuppe" der Mutter nach oben zeigt.

Richte die äußere Bohrung des dünnen Verbindungsstücks und die selbstsichernde Mutter aus und ziehe alles mit einer M8 x 45 Rundkopfschraube (Teil 2) und einem 5 mm-Innensechskant handfest an.

Schiebe das zugehörige Seitenprofil über die zwei Verbindungsstücke und denk daran, eine selbstsichernde Mutter einzusetzen. Befestige auch diese Verbindung mit einer m8 x 45 Rundkopfschraube. Wiederhole die oben beschriebenen Schritte für die andere Seite.

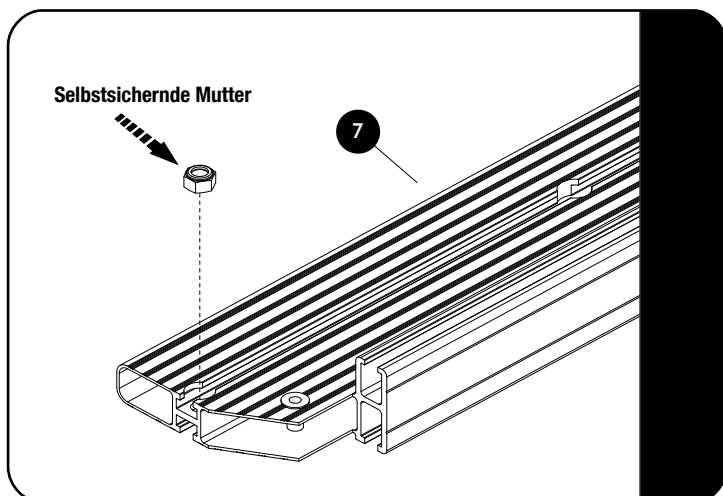

**3****MONTAGE DER ERSTEN KOMBILEISTE****3.1**

Schau Dir die Kombileiste an (Teil 7) und stell sicher, dass in jeder Endaussparung jeweils eine selbstsichernde Mutter eingesetzt ist. Falls die selbstsichernde Mutter während des Transports herausgefallen sein sollte, setze sie mit der "Kuppe" nach oben zurück in die Aussparung (Abb. 3.1).

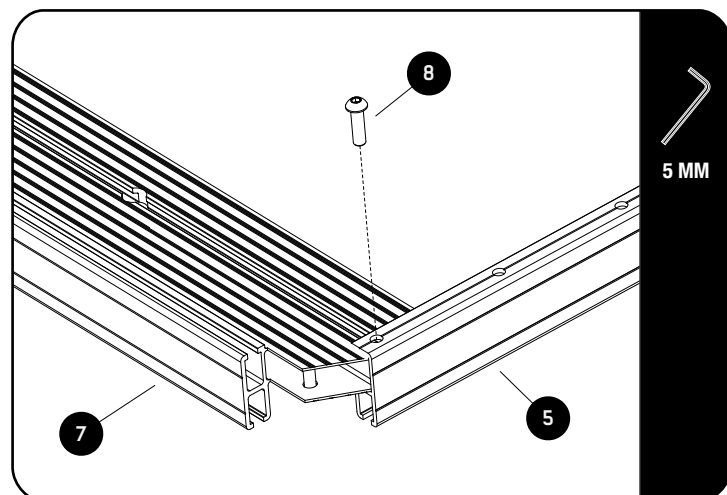
**3.2**

Drehe die Kombileiste (Teil 7) einmal um, sodass die Unterseite nach oben zeigt (Abb. 3.2). Schiebe die beiden Seitenprofile über die Kombileiste und richte die Bohrungen aus. Die Endbohrung des Seitenprofils sollte auf einer Höhe mit der Bohrung der Kombileiste sein.

Verwende eine M8 x 25 Rundkopfschraube (Teil 8) und ziehe sie mit einem 5 mm-Innensechskantschlüssel fest.

Die Plattform bleibt mit der Unterseite nach oben gedreht, für die Montage der 7 Querleisten.

## 4 MONTAGE DER QUERLEISTEN

4.1

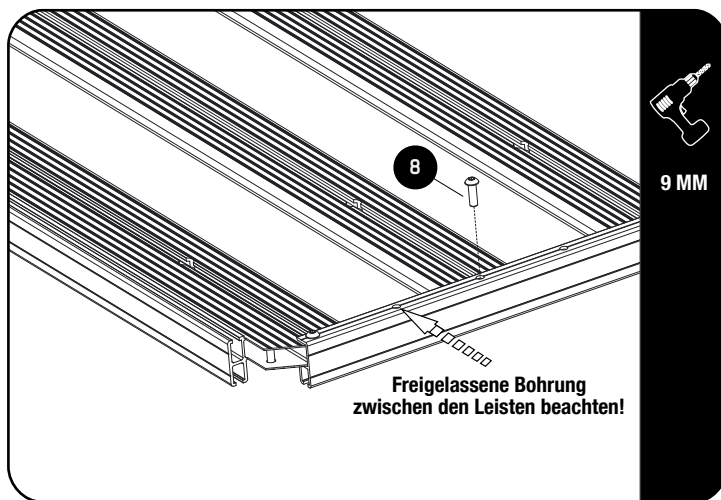

Nimm eine Querleiste (Teil 9) und vergewissere Dich genau wie bei der Kombineleiste, dass die selbstsichernde Mutter in die eingearbeitete Endaussparung eingesetzt ist. Schiebe die Querleiste zwischen die zwei Seitenprofile, wobei die Seite mit der selbstsichernden Mutter nach unten zeigen muss. Positioniere die Querleiste so, dass die Bohrung in der Leiste mit der dritten Bohrung im Seitenprofil ausgerichtet ist (Abb. 4.1).

Verwende eine M8 x 25 Rundkopfschraube (Teil 8) und ziehe sie mit einem 5 mm-Innensechskantschlüssel leicht an dem Seitenprofil an.

Wiederhole diesen Prozess mit den verbleibenden Querleisten und lass immer eine Bohrung in den Seitenprofilen zwischen den Leisten aus (Abb. 4.1).

## 5 MONTAGE DER ZWEITEN KOMBILEISTE

5.1 Schau Dir nochmal Schritt 3.1 an - Schiebe danach die zweite Kombineleiste in die zwei Seitenprofile und befestige sie, wie in Schritt 3.2 beschrieben.

## 6 FESTZIEHEN ALLER SCHRAUBEN

6.1 Ziehe mit Deinem 5 mm-Innensechskantschlüssel alle Rundkopfschrauben fest.



Das empfohlene Drehmoment für die M8 Rundkopfschrauben ist 20 Nm oder 15 ftlb.

## 7 MONTAGE DER DACHTRÄGER-ECKEN

7.1

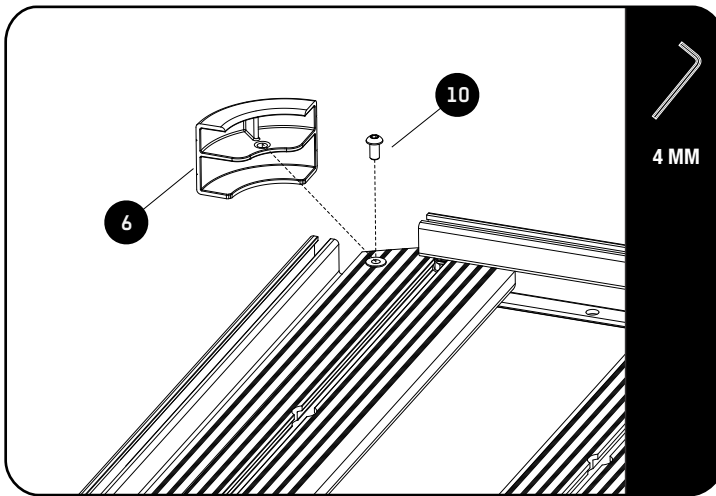

Dreh die Plattform herum, sodass die Oberseite wieder nach oben zeigt.

Schiebe das Eckstück wie dargestellt an seine Position und richte dabei die Bohrung im Eckstück mit der bereits in der Kombileiste eingesetzten Einziehmutter aus. Nimm einen 4 mm-Innensechskant und eine M6 x 12 Rundkopfschraube (Teil 10) und ziehe das Eckstück in der Position fest.

**HINWEIS:** Wenn Du bei der Montage des Slimline II Dachträgers an Deinem Fahrzeug auch gleichzeitig Zubehör anbringen möchtest, solltest Du die Eckstücke zunächst weglassen. Vergewissere Dich in der jeweiligen Montageanleitung, ob das der Fall ist.

## 8 MONTAGE DES WINDABWEISERS

### INHALT

1	1	Slimline II Dachträger
2	4	M8 Halbmutter
3	2	Windabweiser (1L + 1R)
4	4	Unterlegscheibe
5	4	M8 x 12 Rundkopfschraube

### DU BENÖTIGST



ABBILDUNG 1.2



## 8 MONTAGE DES WINDABWEISERS

**HINWEIS:** Der Windabweiser wird an der vorderen Kombileiste montiert.

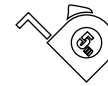
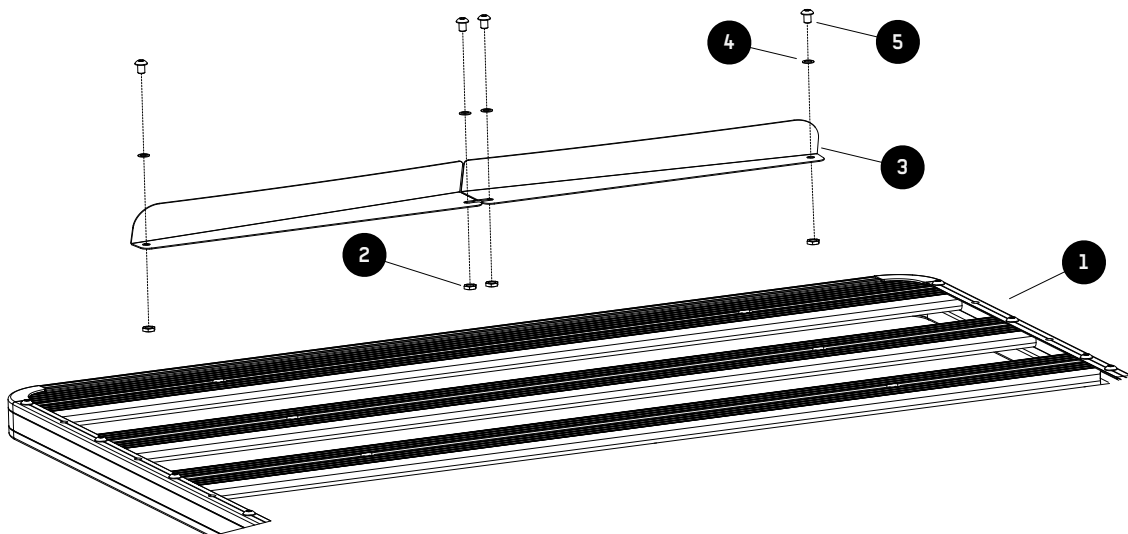

Falls Du ein Befestigungsfuß oder -bein an der Kombileiste montieren musst, musst Du die entsprechende M8 Schraube zur Befestigung in die eingearbeitete Nut der Kombileiste schieben, vor der Montage des Windabweisers.

8.1



Vergewissere Dich, dass Dein Slimline II Dachträger umgedreht, mit der Oberseite nach unten liegt. Das kannst Du an dem Logo erkennen, indem es wie in Abb. 8.1 auf dem Kopf steht.

8.2

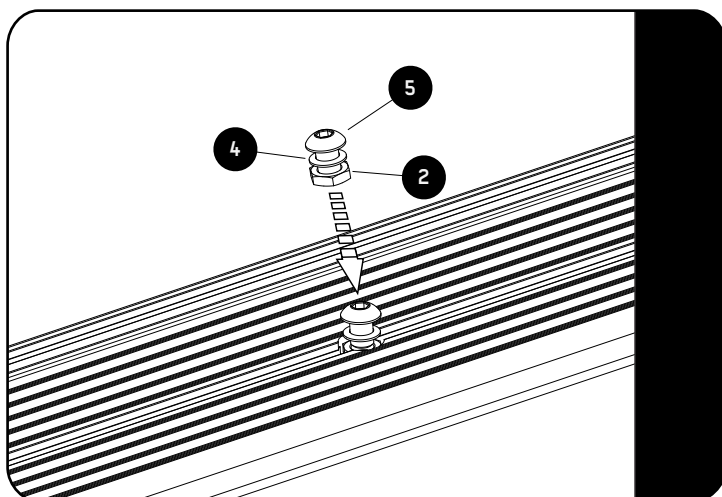

Setze zwei Rundkopfschrauben, M8 Halbmuttern und Unterlegscheiben (Teil 2, 4 & 5) wie dargestellt in die Kombileiste. Schiebe sie bis zur Mitte der Kombileiste, wobei Du sicherstellen musst, dass die Unterlegscheibe über der T-Nut sitzt.

8.3

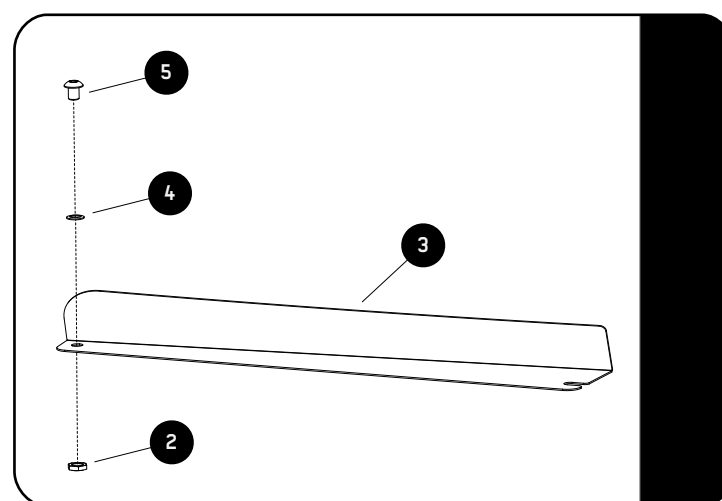

Montiere Teil 2, 4 & 5 wie abgebildet an beiden Windabweisern.

8.4

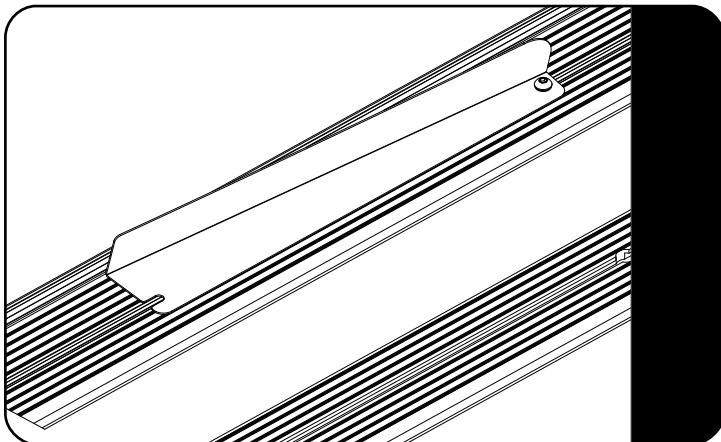

Schiebe die zusammengesetzte Schraube, die am Windabweiser befestigt ist, in die T-Nut der Kombileiste (Abb. 8.4). Die Schraube muss zur Seite des Slimline II Dachträgers zeigen.

Wiederhole diesen Schritt für die andere Hälfte des Windabweisers.

8.5

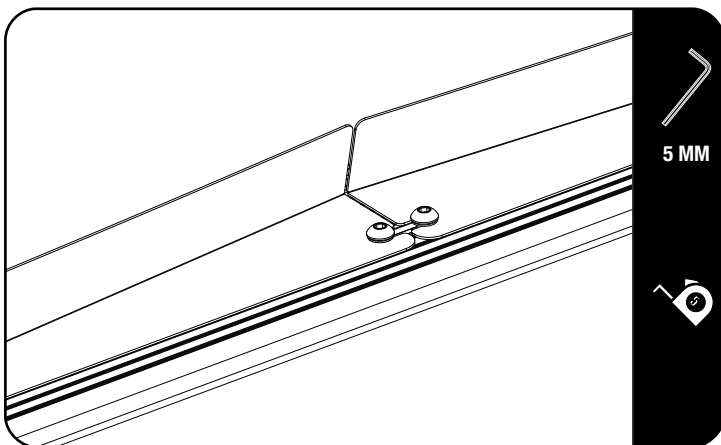

Schiebe beide Hälften des Windabweisers bis zur Mitte der Kombileiste und richte sie mittig zur Außenkante mit Hilfe eines Maßbandes aus.

Setze nun die verbliebenen, zusammengesetzten Schrauben in die T-Nut ein, wie auf Abb. 8.5 und ziehe sie mit einem 5 mm-Innensechskant fest.



**HINWEIS:** Sobald Du den Dachträger an Deinem Fahrzeug montiert hast, mach eine Probefahrt. Solltest Du laute Windgeräusche feststellen, versuche die Position der Windabweiser leicht zu verändern, indem Du sie 20 - 30 mm auseinander ziehst.



**HILFREICHER TIPP – VORHERIGE MONTAGE VON RINGSCHRAUBEN**

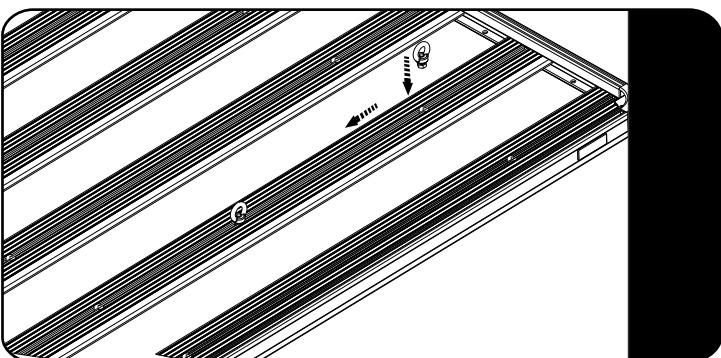

Es ist hilfreich, wenn Ringschrauben (RRAC012) am Dachträger vor der Montage von zusätzlicher Ausrüstung bereits vorhanden sind. Einfach die Ringschrauben in die T-Nut auf den Leisten in der Mitte befestigen und somit vorbereitet sein, falls weitere Accessoires und Ausrüstung montiert werden soll.

## 9 LESE DIE FAHRZEUGSPEZIFISCHE MONTAGEANLEITUNG ZUR BEFESTIGUNG

- 9.1 Nachdem Du die Plattform für Deinen Slimline II Dachträger montiert hast, lese Dir die Montageanleitung für Dein fahrzeug-spezifisches Dachträger Kit durch und folge den Anweisungen zur Installation des Slimline II an Deinem Fahrzeug.

## 10 WIE DU DEINE FRONT RUNNER AUSTRÜSTUNG PFLEGST

EGAL, OB DU DEINEN DACHTRÄGER LIEBER SCHMUTZIG ODER SAUBER MAGST...

...Deine Ausrüstung wird Dir auch über Jahre viel Freude bereiten. Um die beste und dauerhafteste Funktionalität des Dachträgers und insbesondere aller Öffnungen und beweglichen Teile zu gewährleisten, solltest Du Deiner Ausrüstung hin und wieder eine kleine Pflege gönnen.

Spüle Deine Ausrüstung mit klarem Wasser und wische sie mit einem weichen Tuch ab. Bei hartnäckigem Schmutz verwende eine weiche Bürste und etwas Seife.

Falls Du Deiner Ausrüstung etwas Gutes tun möchtest, kannst Du gerne etwas Wachs oder ein vor UV-Strahlung schützendes Spray verwenden. Stelle nur sicher, dass das verwendete Wachs keine Polierkörner beinhaltet.



Im salzigen Küstenklima oder verschneiten Regionen, in denen Streusalz auf den Straßen genutzt wird, verwende auf Silikonbasis beschaffenes Öl oder Spray, um die Muttern und Schrauben dauerhaft vor Korrosion zu schützen.

## 11 HOL DIR NOCH MEHR AUSTRÜSTUNG VON FRONT RUNNER

Besuche uns Online auf [www.FrontRunnerOutfitters.com](http://www.FrontRunnerOutfitters.com)

Markiere uns immer und überall! #FrontRunnerOutfitters #BornToRoam

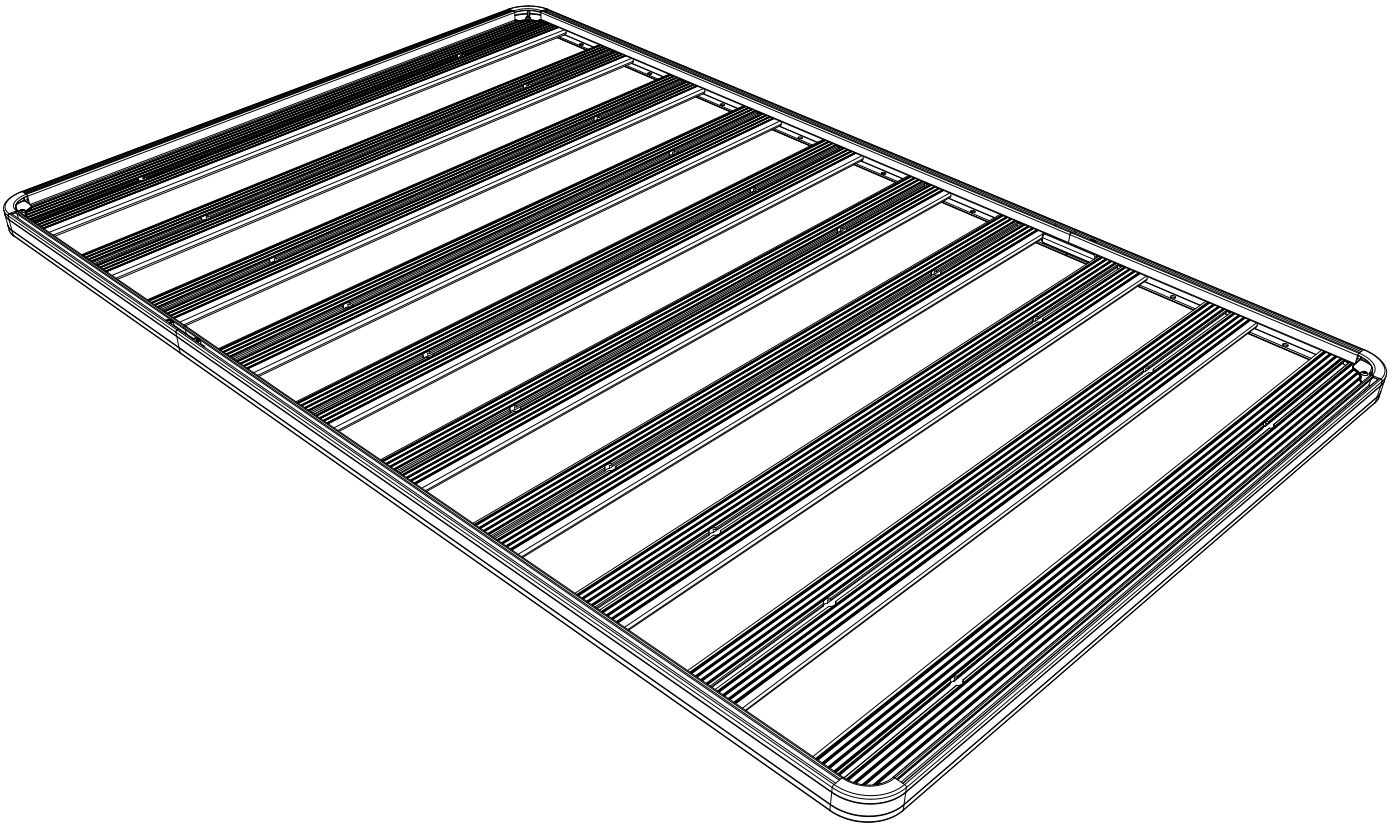
Teile Deine Abenteuer auf:    

**¡Léeme!** 

Gracias por comprar una baka portaequipaje Slimline II de Front Runner. Antes de empezar, tóme un momento para familiarizarse con las instrucciones de instalación y los componentes recibidos. Consulte la página 2 para obtener una lista de todos los componentes, las cantidades y las herramientas requeridas.

**¡ADVERTENCIA IMPORTANTE!** 

ES FUNDAMENTAL QUE TODOS LOS PRODUCTOS DE FRONT RUNNER SE ENSEMBLEN DE FORMA ADECUADA Y SEGURA Y SE ADJUNTEN A SU VEHÍCULO. LA COLOCACIÓN INADECUADA PODRÍA RESULTAR EN UN ACCIDENTE AUTOMOVILÍSTICO, Y PODRÍA CAUSAR LESIONES CORPORALES GRAVES O LA MUERTE. USTED ES RESPONSABLE DE ENSAMBLAR Y ASEGURAR TODOS LOS PRODUCTOS FRONT RUNNER A SU VEHÍCULO, VERIFICAR LOS ACCESORIOS ANTES DE USARLOS E INSPECCIONAR PERIÓDICAMENTE LOS PRODUCTOS PARA SU AJUSTE, DESGASTE Y DAÑOS. POR LO TANTO, DEBE LEER Y COMPRENDER TODAS LAS INSTRUCCIONES Y PRECAUCIONES SUMINISTRADAS CON SU PRODUCTO FRONT RUNNER ANTES DE LA INSTALACIÓN O EL USO. SI USTED NO ENTIENDE TODAS LAS INSTRUCCIONES Y PRECAUCIONES, O SI NO TIENE EXPERIENCIA MECÁNICA Y NO ESTÁ COMPLETAMENTE FAMILIARIZADO CON LOS PROCEDIMIENTOS DE INSTALACIÓN, DEBE DE INSTALAR EL PRODUCTO POR MEDIO DE UN INSTALADOR PROFESIONAL U OTRO PERSONAL CAPACITADO.

**Nota:** Front Runner no será responsable de los daños causados por la imposibilidad de instalar el producto de acuerdo con estas instrucciones. Por favor llámenos si tiene alguna pregunta sobre la instalación de este producto.

# 1 ORGANÍZATE

Dependiendo del tamaño de baka portaequipaje Slimline II ordenado, las cantidades mostradas pueden variar.

A continuación, es lo que se busca para RRSUNI:

EN LA CAJA		
1	32 X	Tuerca Nyloc M8
2	4 X	M8 x 45 Tornillo cabeza de botón
3	2 X	Pieza de ensamble gruesa
4	2 X	Pieza de ensamble delgada
5	4 X	Perfil lateral
6	4 X	Esquina
7	2 X	Barra combinada
8	28 X	M8 x 25 Tornillo cabeza de botón
9	12 X	Barra estándar
10	4 X	M6 x 10 Tornillo cabeza de botón

### HERRAMIENTAS NECESARIAS



4mm  
5mm

FIGURA 1.1

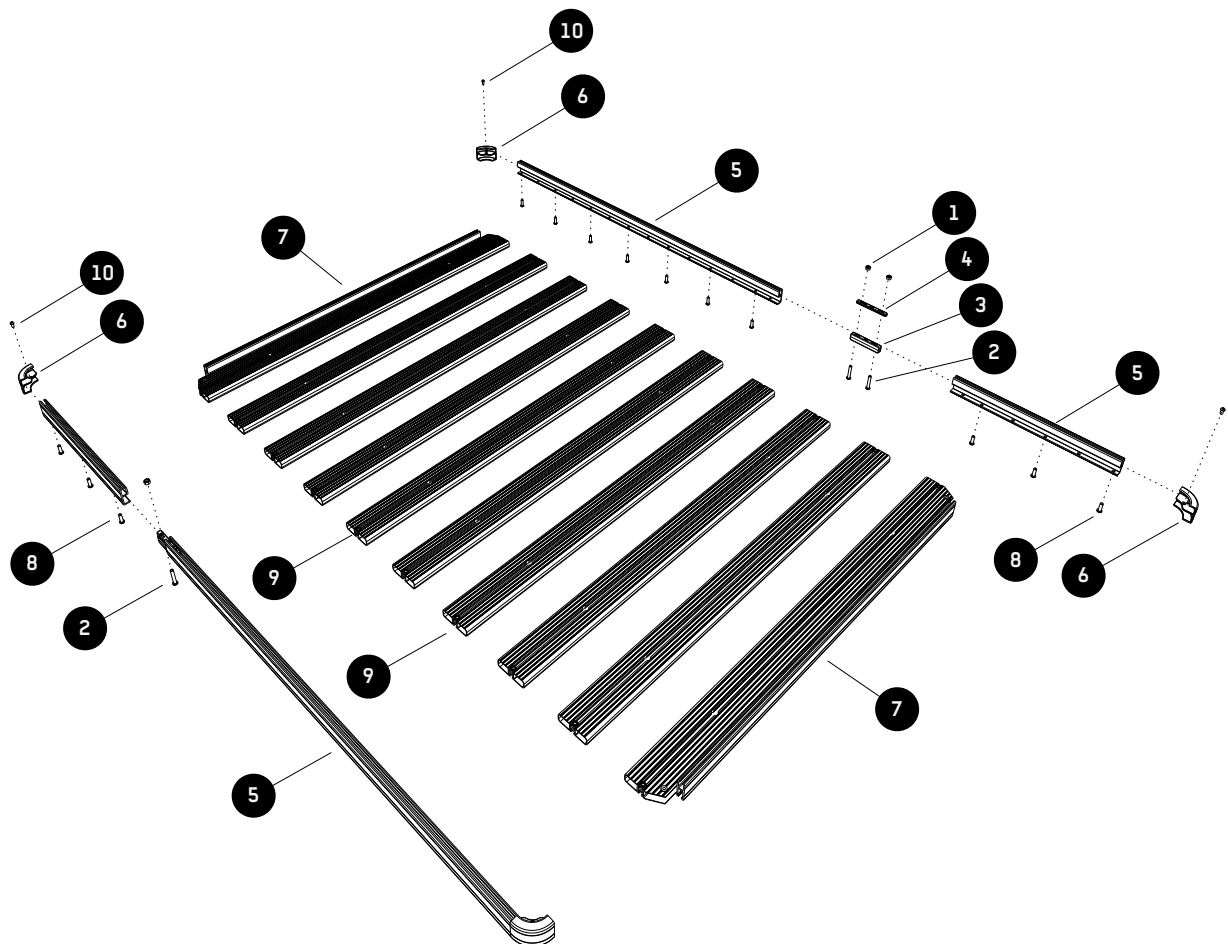





**Nota:** Omite este paso si su baka portaequipaje Slimline II es de 1560mm o más corta. Sólo tendrá dos perfiles laterales y no es necesario el montaje.

Si usted ha recibido cuatro longitudes de perfil lateral (artículo 5), tendrá que unir las piezas juntas utilizando las piezas de ensamble (artículos 3 & 4) para formar sólo dos longitudes siguiendo los sencillos pasos a continuación.

Con la excepción de la baka Slimline II de 2772mm de largo, las articulaciones del perfil lateral estarán diagonalmente opuestas una vez que se haya montado la bandeja.

2.1

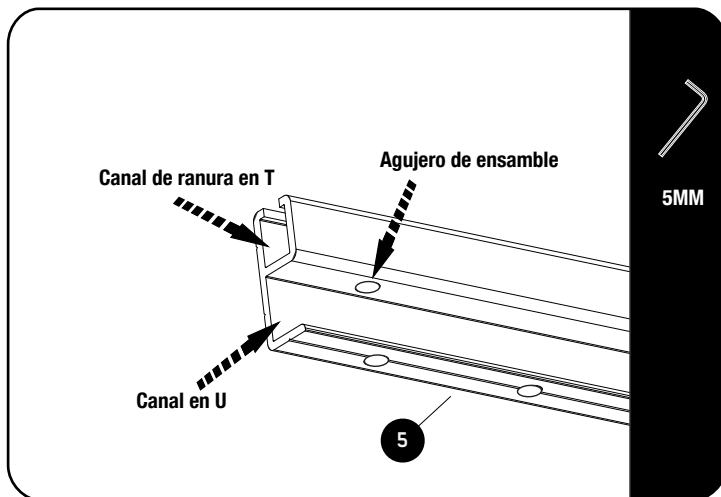

Los perfiles laterales se suministran en pares. Tome un perfil de cada par, uno corto y uno largo (excepto para la baka Slimline II de 2772mm de largo, donde los perfiles laterales serán de igual longitud. Aunque ambos pares tienen la misma longitud, sigue siendo importante que usted tome un perfil lateral de cada par).

Si nos fijamos en los perfiles laterales se verá que en un extremo hay un agujero que va a través de la parte superior e inferior del canal "U".

(Consulte la imagen 2.1).  
Estos son los agujeros de unión que va a utilizar.

2.2

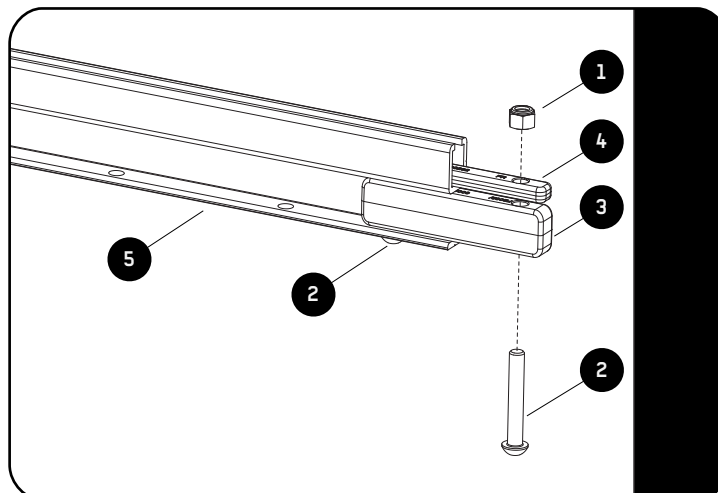

Inserte un ensamble grueso (punto 3) en el canal "U" del perfil lateral alineando el primer orificio con el orificio en el perfil lateral como se muestra en 2.2.

Ahora coge un ensamble delgado (punto 4) y tuerca nyloc (artículo 1). Deslice el ensamble en la "ranura en T", seguido de una tuerca nyloc. La tuerca nyloc debe sentarse en la parte superior del ensamble delgado con la "cúpula" de la tuerca nyloc hacia arriba. Alinee el orificio exterior del ensamble delgado y la tuerca nyloc con el agujero de ensamble y apriete libremente todo junto con un tornillo cabeza de botón M8 x 45 (artículo 2) y una llave Allen de 5mm.

Deslice el perfil lateral coincidente sobre las dos piezas de ensamble, recordando insertar una tuerca nyloc, y apriete una vez más usando un tornillo cabeza de botón M8 x 45. Repite los pasos anteriores para el otro lado.

3.1

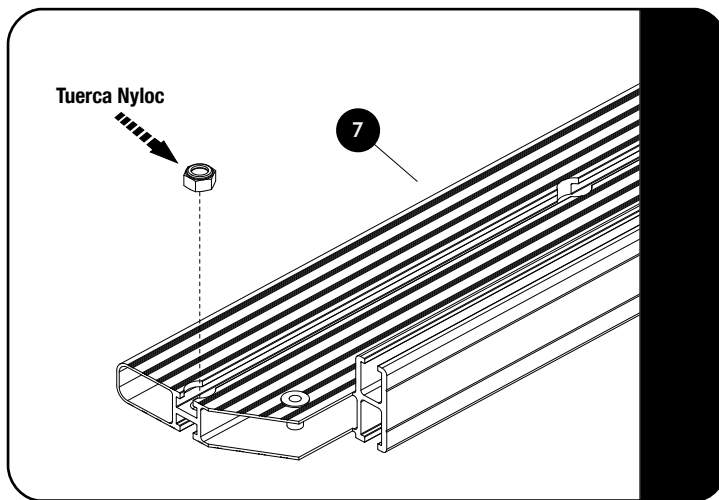

Mire la barra combinada (artículo 7) y asegúrese de que haya una tuerca nyloc insertada en cada bolsillo final mecanizado. Si la tuerca nyloc se ha caído durante el envío, insértala de nuevo en el bolsillo como se muestra en la figura 3.1.

3.2

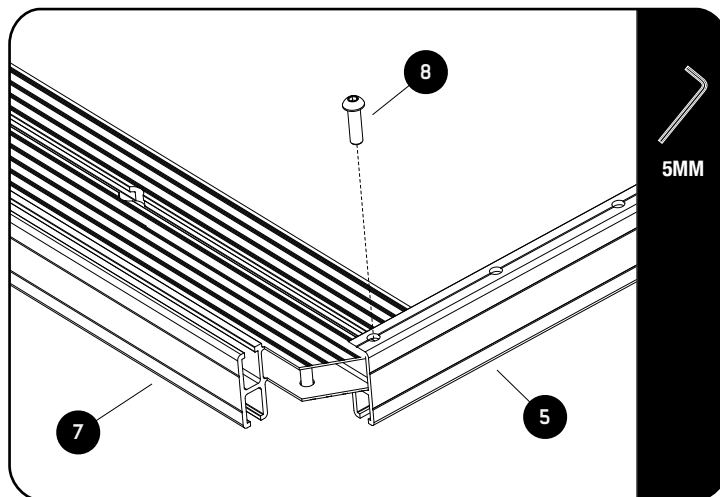

Gire la barra combinada (artículo 7) boca abajo como se muestra. Deslice los perfiles laterales (artículo 5) sobre la barra combinada y alinee los agujeros. El orificio final del perfil lateral debe alinearse con el orificio en la barra combinada. Utilice un cabeza de botón M8 x 25 (artículo 8) y apriete ligeramente con una llave Allen de 5mm.

**4**

## MONTAJE DE BACA - BARRAS ESTÁNDAR

4.1

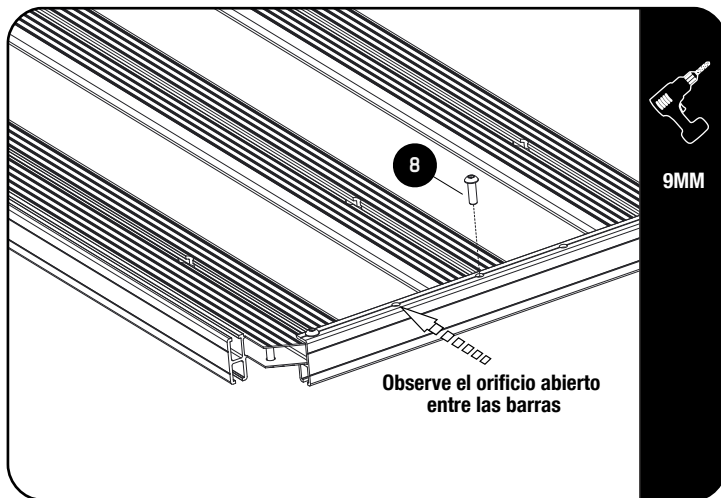

Tome una barra estándar (artículo 9) y, al igual que con la barra combinada, asegúrese de que la tuerca Nyloc está en el bolsillo del extremo mecanizado. Deslice la barra estándar entre los dos perfiles laterales con la tuerca Nyloc en la parte inferior. Posicione la barra de modo que el orificio en la barra se alinee con el tercer orificio en el perfil lateral como se muestra en la figura 4.1.

Repita el proceso para las barras estándar restantes asegurándose de que hay un orificio abierto en el perfil lateral entre cada barra. Refiera a la figura 1.1.

Utilice un tornillo cabeza de botón M8 x 25 (artículo 8) y fije ligeramente la barra estándar al perfil lateral con una llave Allen de 5mm.

**5**

## MONTAJE DE BACA - BARRA COMBINADA

5.1 Revisión paso 3.1- a continuación, deslice la segunda barra combinada en los dos perfiles laterales y fije de acuerdo a la figura 3.2.

**6**

## MONTAJE DE BACA - TORNILLOS DE SUJECIÓN

6.1 Con su llave Allen de 5mm, apriete todos los tornillos cabeza de botón.



El ajuste de par recomendado para los tornillos cabeza de botón M8 es de 20 Nm o 15 ft lb.



**Nota:** El deflector de viento debe estar montado en la parte delantera de la barra combinada. Si va a poner una pata o pie en la barra combinada (recomendado), tendrá que deslizar el tornillo M8 utilizado para colocar estos en las ranuras mecanizadas antes de ensamblar el deflector de viento.

8.1



Asegúrese de que la baka portaequipaje Slimline II esté al revés. Consulte la etiqueta del producto. Debe estar al revés como se muestra.

8.2

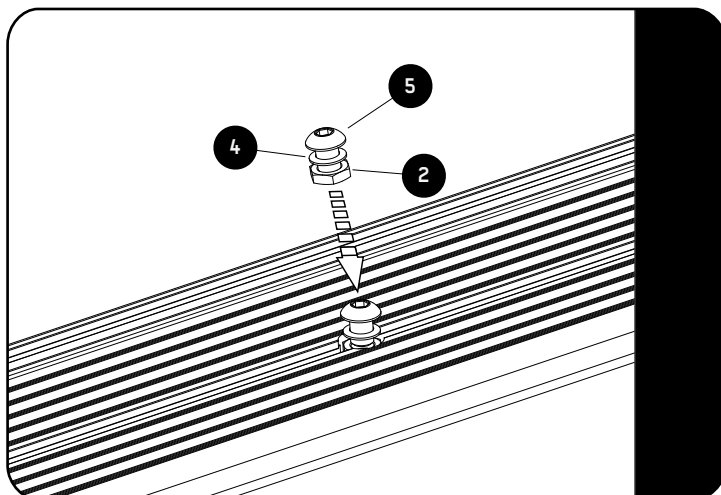

Inserte dos tornillos cabeza de botón, M8 medias tuercas y arandelas de seguridad Schnorr (artículos 2, 4 & 5) en la barra combinada como se muestra. Deslicelo hacia el centro de la barra combinada asegurándose de que la arandela Schnorr está por encima del canal ranura en T.

8.3

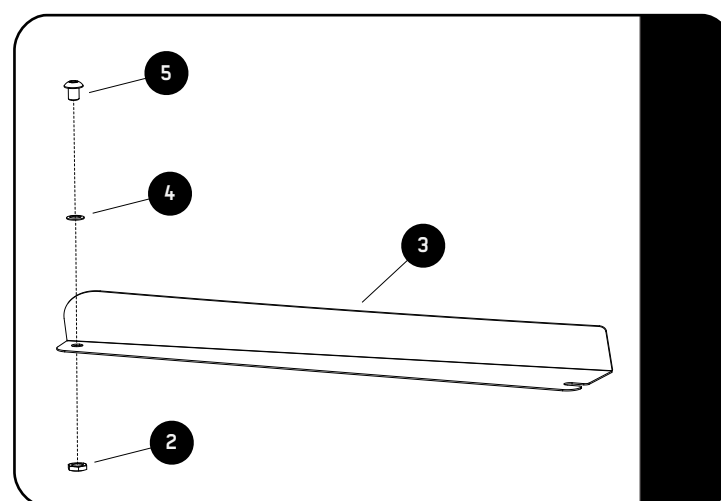

Ensamble los elementos 2, 4 y 5 a ambos deflectores de viento LH & RH (artículo 3) como se muestra.

**7**

**MONTAJE DE BACA - ESQUINAS**

7.1

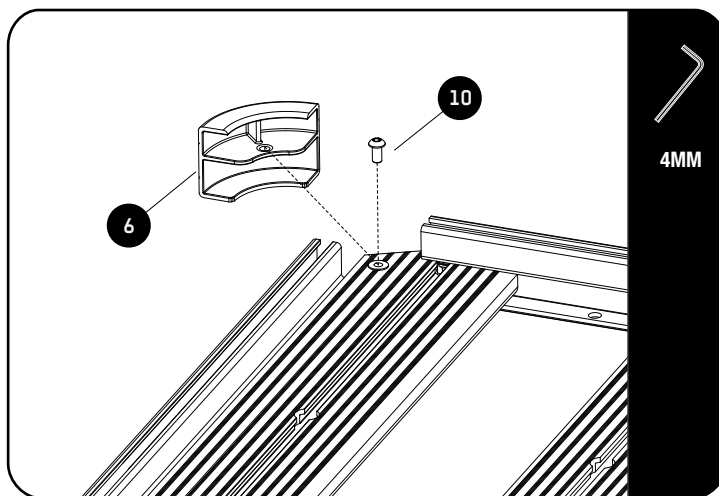

Voltear la baca boca arriba.

Empuje la esquina en la posición como se muestra, alineando el agujero en la esquina con el Rivnut ya insertado en la barra combinada. Utilice un tornillo cabeza de botón M6 x 12 (artículo 10) y fije la esquina en posición.

**8**

**MONTAJE DE BACA - DEFLECTOR DE VIENTO**

**EN LA CAJA**

1	1	Baca portaequipaje Slimline II
2	4	M8 Tornillo medio
3	2	Deflector de viento (1LH + 1RH)
4	4	Arandela de seguridad Schnorr
5	4	M8 x 12 Tornillo cabeza de botón

**HERRAMIENTAS NECESARIAS**



FIGURA 1.2



**6****MONTAJE DE BACA - DEFLECTOR DE VIENTO**

6.4

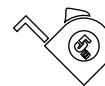
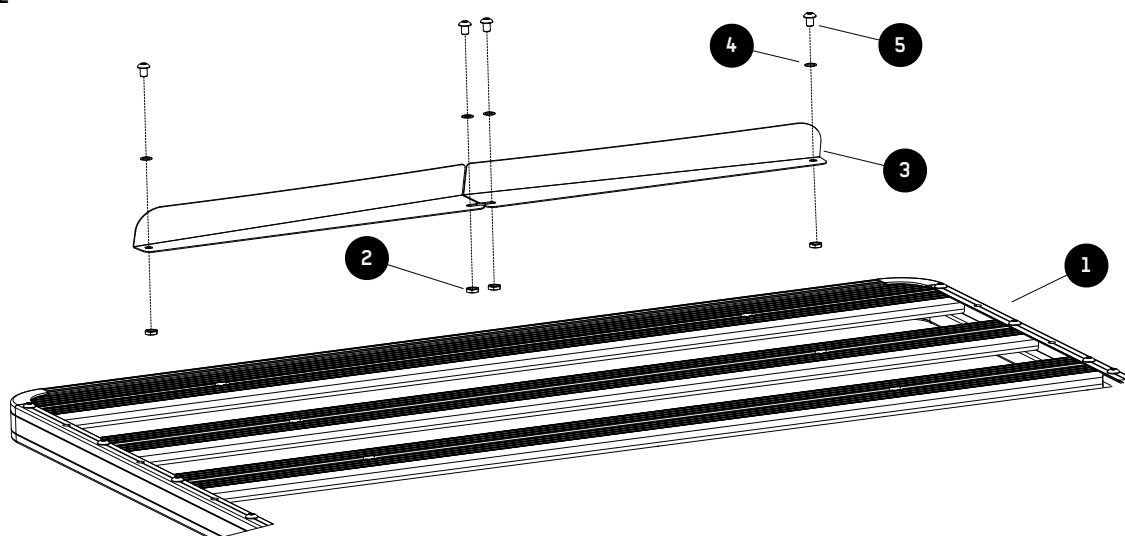
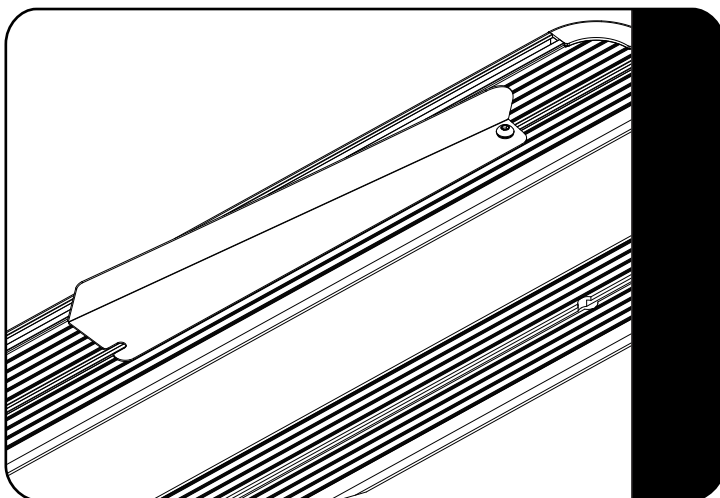

Inserte la tuerca montada en el deflector de viento en el bolsillo combinado de la ranura en T y deslicela hacia el costado como se muestra en la figura 8.4. Repite para la otra mitad del deflector de viento.

6.5

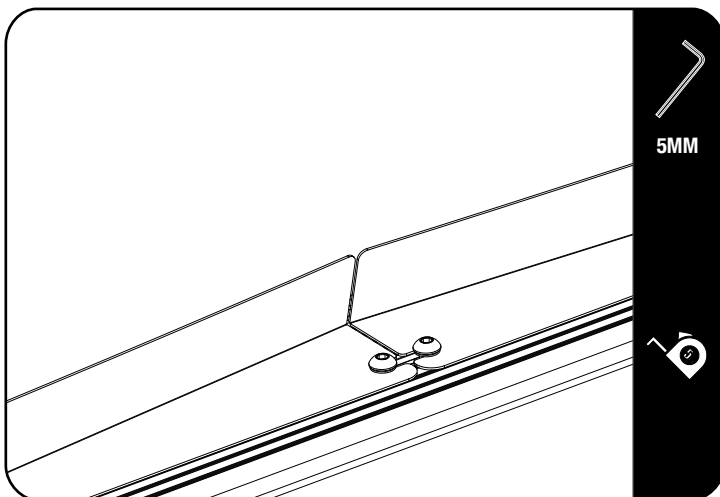

Centrar el deflector de viento en la baka y mover los conjuntos de tornillos de la figura 8.2 en las ranuras como se muestra en la figura 8.5.

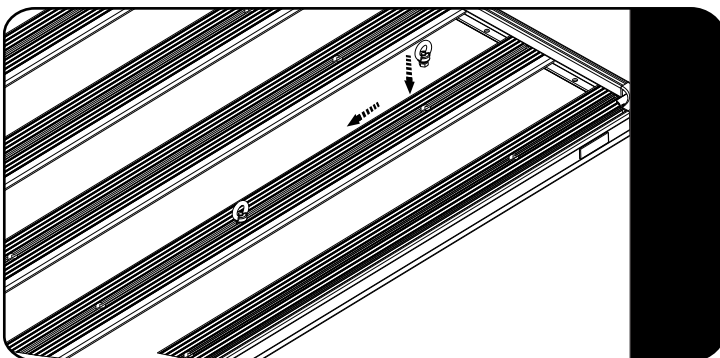

**Nota:** Una vez que el bastidor está montado en el vehículo, se recomienda hacer una prueba de manejo. En el supuesto de que haya ruido excesivo del viento intente mover los dos deflectores ligeramente separados, dejando un hueco de unos 20-30mm.

**CONSEJO ÚTIL - ANILLOS DE AMARRE DE PRECARGA**

Es de mucha utilidad el colocar los anillos de amarre (RRAC012) en la baka portaequipajes de Front Runner para su uso futuro antes de colocar cualquier accesorio.

Inserte los anillos de amarre por medio de las ranuras y colóquelos en el centro de la baka de techo.

**9**

## CONSULTE LA GUÍA DE INSTALACIÓN DE SU VEHÍCULO

9.1

Ahora que su baca portaequipaje Slimline II está montada, obtenga la guía de instalación del juego de baca y siga las instrucciones para ajustar la Slimline II a su vehículo específico.

**10**

## CÓMO CUIDAR DE SU EQUIPO FRONT RUNNER

### LAS BACAS Y ACCESORIOS DE FRONT RUNNER SON MÁS FELICES CUBIERTOS DE LODO

Pero para poder mantener la funcionalidad completa de las ranuras de la baca y las partes móviles, es posible que desee dar a su equipo un baño de vez en cuando.

¡Es fácil! Cuida tu equipo Front Runner de la misma manera que haces con el exterior de tu vehículo:

Enjuague con agua limpia y limpie con un paño suave y seco. Para manchas persistentes, usa un cepillo suave y un jabón suave.

Si realmente quieres cuidar tu equipo, puedes encerar ligeramente las superficies o utiliza un aerosol protector con inhibidores para rayos solares UV. Solo asegurate de no utilizar ceras compuestas que contienen abrasivos.

En climas costeros salados, o regiones nevadas donde la sal se utiliza para despejar las carreteras, aplicar un aceite o aerosol basado en silicona en tuercas y tornillos ayudará a prevenir la corrosión.

**¡YA SEA QUE TE GUSTE RODAR SUCIO O LIMPIO, SU EQUIPO FRONT RUNNER LE DARÁ MUCHOS AÑOS DE SERVICIO!**

**11**

## INSTALAR OTROS ACCESORIOS PARA EL VEHÍCULO Y DE BACA

Ahora es el momento de visitar su distribuidor favorito de Front Runner en persona o en línea.

Asegúrate de etiquetarnos. ¡Nos encanta ver nuestro equipo en acción!

#FrontRunnerOutfitters #BornToRoam

Comparte tus aventuras en:

