

START HERE!

READ ME FIRST

Don't be a hero and muscle through this installation without reading these fitting instructions first! Improper installation of this gear may void certain aspects of your warranty.

Before you begin, take a moment and open all your Front Runner rack kit boxes and gather the assembly instructions for the various components.

A complete kit will contain:

1. A Front Runner Mounting System specific to your vehicle
2. A Front Runner Rack Tray or Load Bar Slats

This document will guide you through the assembly of the mounting system and assist you in fitting the roof rack tray or load bars to your specific vehicle.

Please refer to the next page for a list of all the components, quantities and tools required.

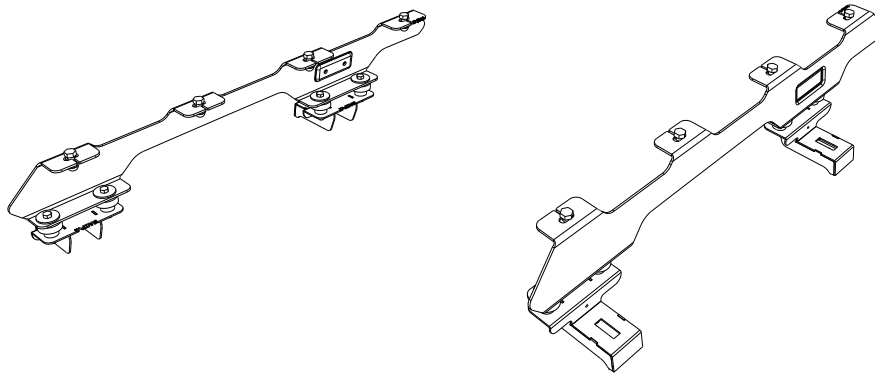

IMPORTANT WARNING! ⚠

IT IS CRITICAL THAT ALL FRONT RUNNER PRODUCTS BE PROPERLY AND SECURELY ASSEMBLED AND ATTACHED TO YOUR VEHICLE. IMPROPER ATTACHMENT COULD RESULT IN AN AUTOMOBILE ACCIDENT, AND COULD CAUSE SERIOUS BODILY INJURY OR DEATH. YOU ARE RESPONSIBLE FOR ASSEMBLING AND SECURING ALL FRONT RUNNER PRODUCTS TO YOUR VEHICLE, CHECKING THE ATTACHMENTS PRIOR TO USE, AND PERIODICALLY INSPECTING THE PRODUCTS FOR ADJUSTMENT, WEAR AND DAMAGE. THEREFORE, YOU MUST READ AND UNDERSTAND ALL OF THE INSTRUCTIONS AND PRECAUTIONS SUPPLIED WITH YOUR FRONT RUNNER PRODUCT PRIOR TO INSTALLATION OR USE. IF YOU DO NOT UNDERSTAND ALL OF THE INSTRUCTIONS AND CAUTIONS, OR IF YOU HAVE NO MECHANICAL EXPERIENCE AND ARE NOT THOROUGHLY FAMILIAR WITH THE INSTALLATION PROCEDURES, YOU SHOULD HAVE THE PRODUCT INSTALLED BY A PROFESSIONAL INSTALLER OR OTHER QUALIFIED PERSONNEL.

NOTE: Front Runner will not be responsible for any damage caused by the failure to install the product according to these instructions.

Please call us if you have any questions about the installation of this product.

1

GET ORGANIZED

FAJT001

IN THE BOX

1	2 X	Foot Rail - 1LH + 1RH
2	8 X	M8 X 20 Hex Bolt
3	8 X	M8 x 16 x 1.6SS Flat Washer
4	8 X	M8 Nyloc Nut
5	8 X	M8 Nut Cap

TOOLS NEEDED



- Vacuum Cleaner
- a Friend



FIGURE 1.2

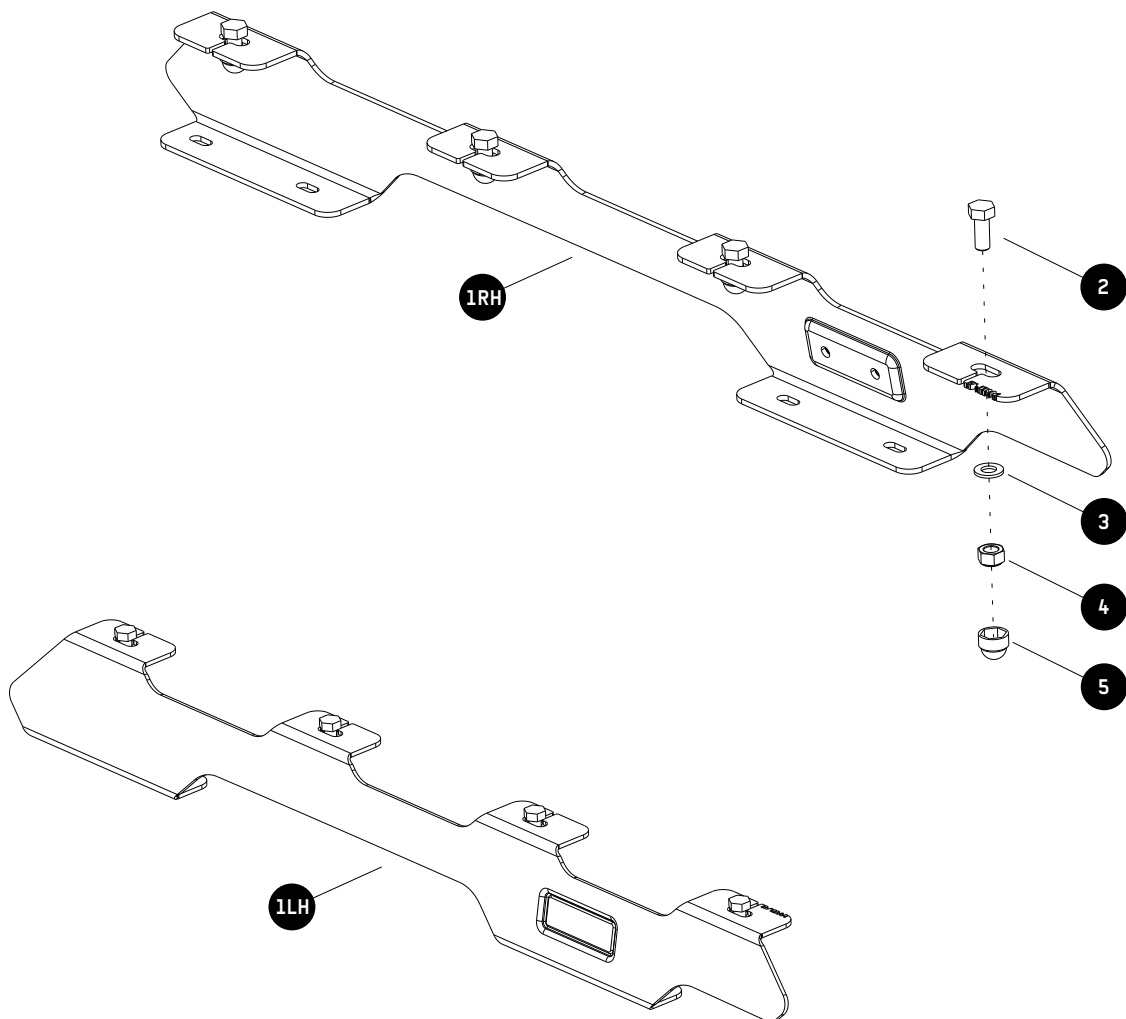

1

GET ORGANIZED

FAJT002

IN THE BOX

6	4 X	Inner Bracket
7	8 X	M6 x 40 Hex Bolt
8	8 X	M6 x 30 x 2 Laser Cut Washer
9	8 X	Foam Seal Washer
10	8 X	Aluminum Spacer
11	8 X	M6 x 12 x 1SS Flat Washer
12	8 X	M6 Nyloc Nut
13	8 X	M6 Nut Cap
14	4 X	M8 Cage Nut
15	4 X	M8 x 19 x 2SS Flat Washer
16	4 X	M8 SS Spring Washer
17	2 X	M8 x 100 Hex Bolt
18	4 X	M8 Nut Cap
19	1 X	Seal Kit

FIGURE 1.1

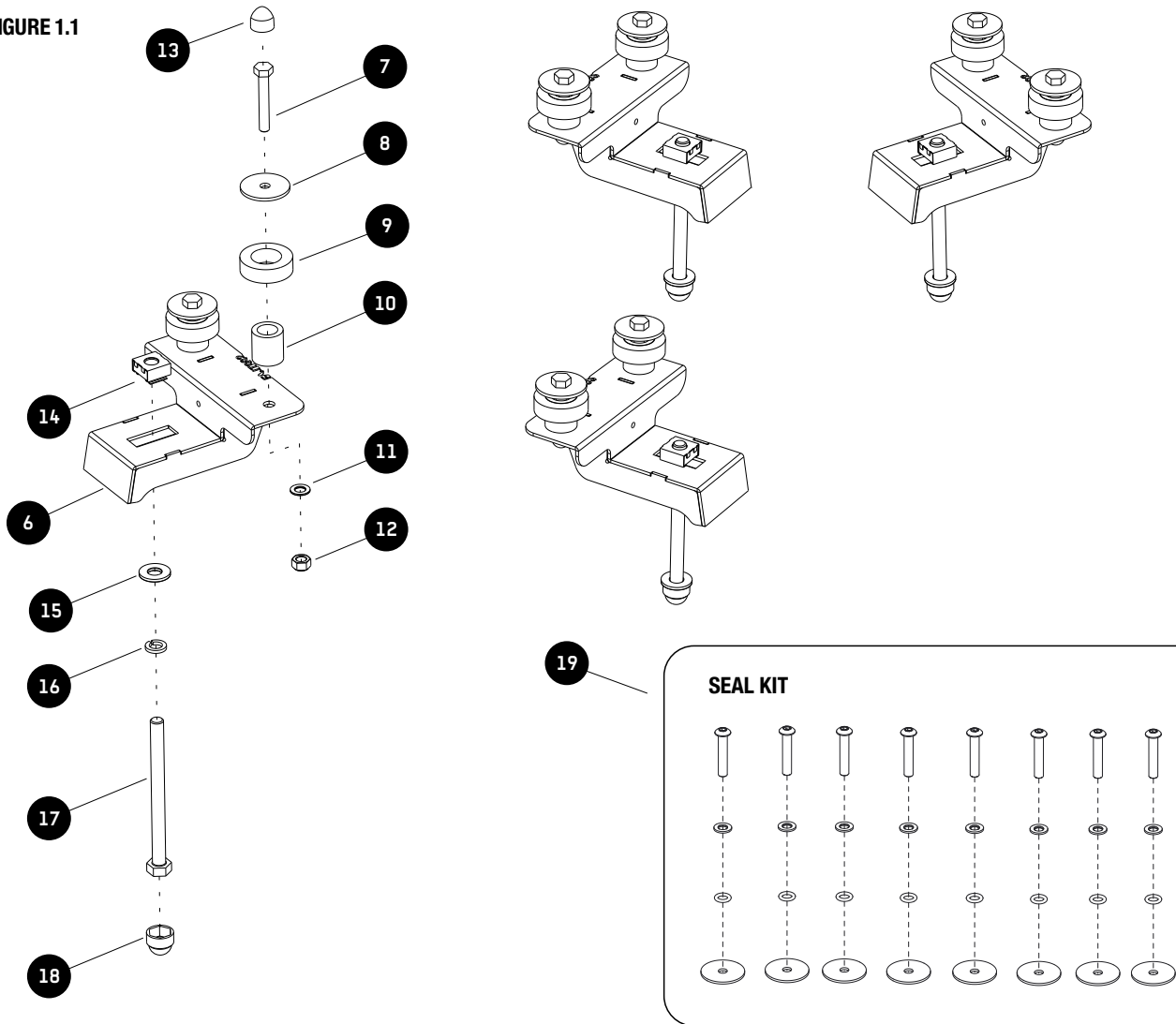

2.1



Looking at the roll cage at the rear passenger door, remove the plastic trim covers located on the inside of the roll bar as shown.

Do this on both the left and right side.

2.2



Remove the speaker box located above the front seats.

2.3

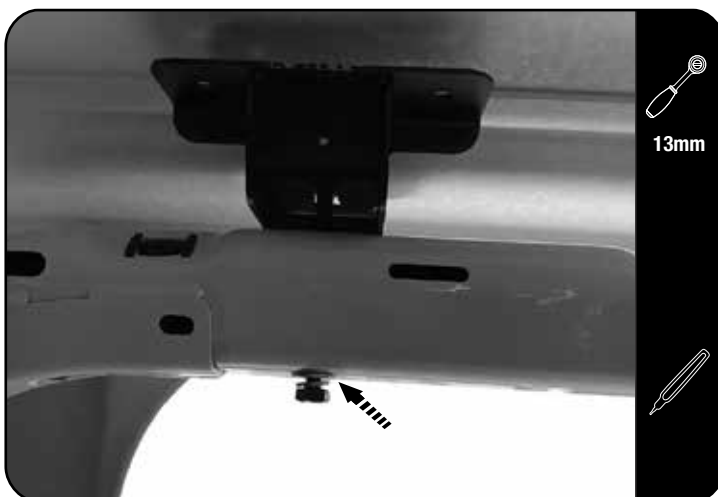

Before fitting the rear Inner Brackets (Item 1), insert the M8 Cage Nuts (Item 14). Refer to Figure 1.1 for assembly of the Cage Nuts.



Locate the back hole shown on the underside of the roll bar, at the rear passenger door.

Fit the Inner Brackets on top of the roll bar and loosely secure them to the roll bar using M8 x 100 Hex Bolts, M8 SS Spring Washers and M8 x 19 x 2SS Flat Washers (Items 15, 16 & 17) as shown.

Refer to Figure 1.1 again if necessary.

Do this on both the left and right side.

Using the two top holes on the Inner Bracket as a guide, mark the hole positions on the roof. Do the same with the opposite side.

You will drill these in 2.4.

2.4

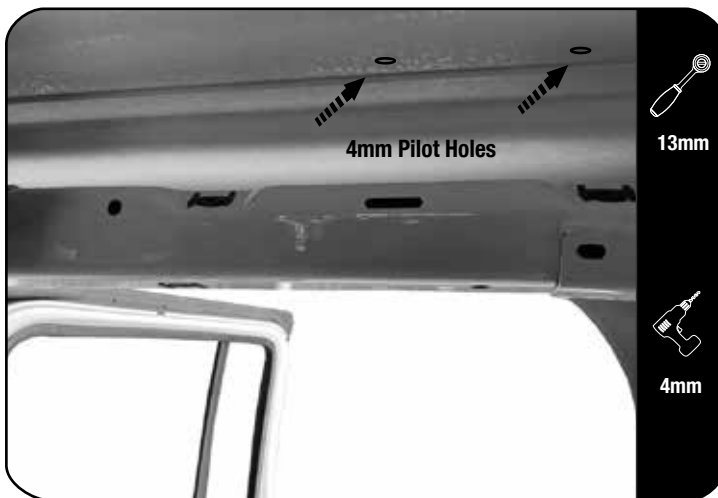

Remove the two brackets.

Have a friend hold a vacuum cleaner with the nozzle attached, close to the drill point.

Using a 4mm drill bit, drill two pilot holes on the marks made earlier.

Do the same on the opposite side.

2.5

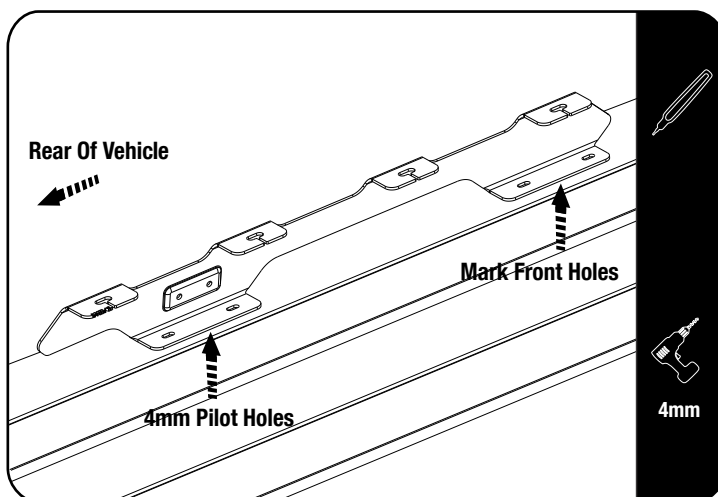

Place the Foot Rail on the roof and align the rear slots of the Foot Rail centre with the holes drilled in 2.4.

Align the Foot Rail with the rib on the roof so that it runs parallel with the rib before marking the two front holes.

Mark the position of the two front holes of the Foot Rail onto the outside of the roof.

Remove the rail and from the outside, drill 4mm pilot holes on the marks just made.

Do this on both sides of the vehicle.

Using the Foot Rail as a template check that all four holes are centered in the slots of the Foot Rail.

2.6



Change the 4mm drill bit to a 22mm hole saw. From the outside of the vehicle, drill all the 4mm holes (8 in total) out to 22mm.

Let the drill do the work. You do not want to scratch or damage your vehicle's roof. Have your friend hold the vacuum cleaner underneath where you are drilling to catch all the dust and keep your vehicle clean.

After drilling, clean the area around all the 22mm holes in the roof with a rag and methylated spirits/denatured alcohol.

2**FIT AND SECURE****2.7**

 Secure the rear Inner Bracket (Item 6) using a M8 x 100 Hex Bolt, M8 SS Spring Washer and M8 x 19 x 2SS Flat Washer. (Items 15, 16 & 17) As shown.
Do this on both sides of the vehicle.

2.8

 Secure the front Inner Bracket (Item 6) using a M8 x 100 Hex Bolt, M8 SS Spring Washer and M8 x 19 x 2SS Flat Washer. (Items 15, 16 & 17) As shown.
Do this on both sides of the vehicle.

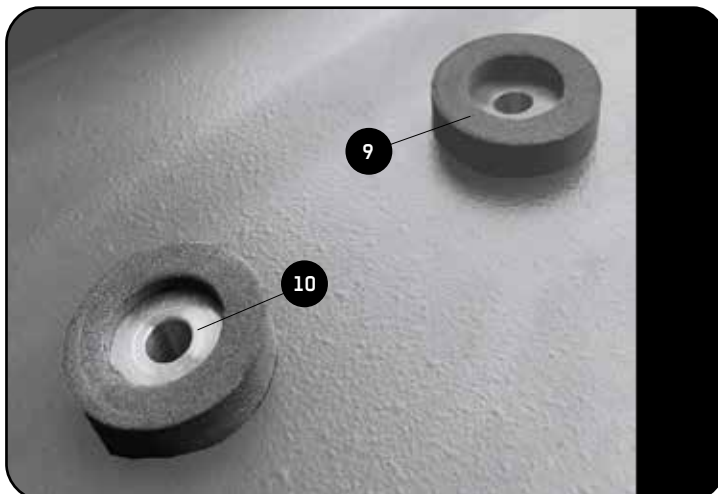
2.9

 Insert the Aluminum Spacers (Item 10) into the Foam gaskets (Item 9). Remove the paper backing from the Foam gaskets to expose the adhesive.
Insert the Washer/Spacer combination, adhesive side down, into the 22mm holes so that the Spacer comes to rest on the Inner Brackets.
Firmly press the Foam gaskets all the way around, adhering it to the roof.

2

FIT AND SECURE

2.10

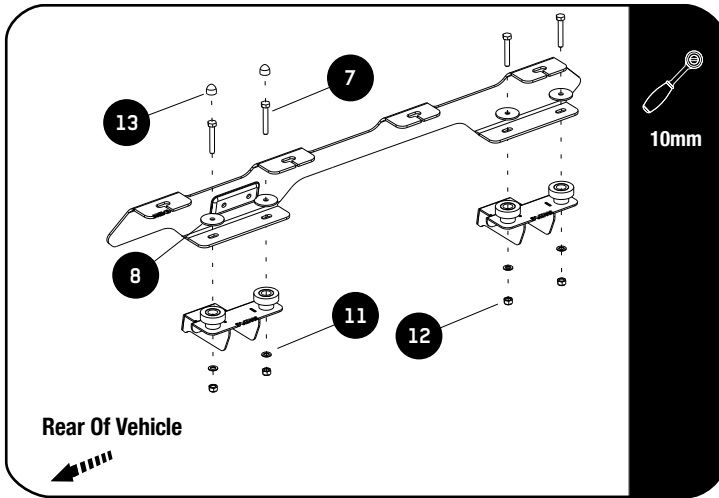

Place the Foot Rail (Item 1) onto the Spacers and secure using M6 x 40 Hex Bolts, M6 x 30 x 2 Flat Washers, M6 x 12 x 1SS Flat Washer and M6 Nyloc Nuts (Items 7, 8, 11 & 12) as shown. Do this on both sides of the vehicle.

Finish off by placing M6 Nut Caps (Item 13) on all the bolt heads.

3

FIT AND SECURE

3.1

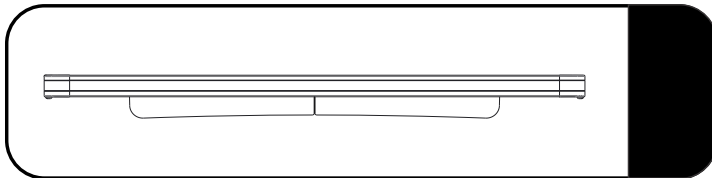

Make sure that the wind deflector is installed before you proceed to the next step.

Refer to Rack Fitment Guide (RRSTUNI).

3.2

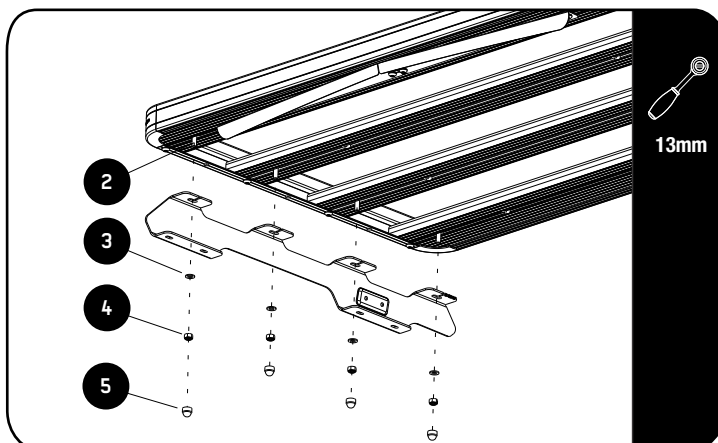

For a Full Rack fitment refer to FAJL004 Fitment Guide (Steps 2.1, 2.2, & 2.6).



Fit your Roof Rack (1/2 Rack shown) to the Foot Rails using M8 x 20 Hex Bolts, M8 x 16 x 1.6SS Flat Washers and M8 Nyloc Nuts (Items 2, 3 & 4).

3.3

Center the rack and tighten fully. Use M8 Nut Caps (Item 5) to finish off the nuts.



4

REMOVING YOUR RACK

2.10

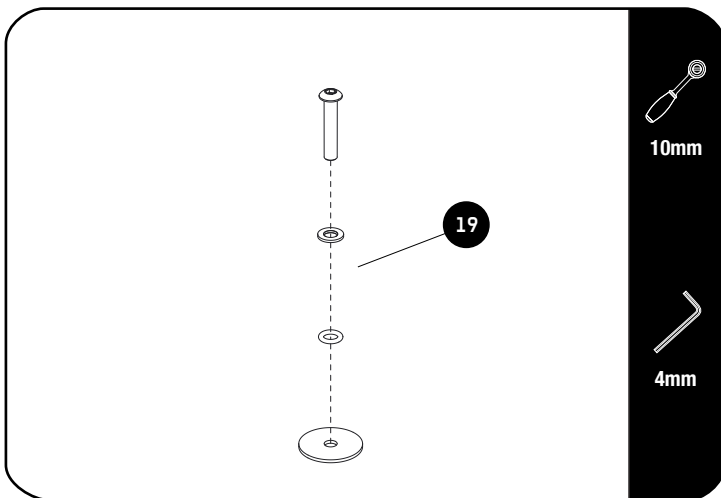

Should you wish to remove your rack, you will need to plug the holes you drilled in the roof using the supplied Seal Kit (Item 19).

Remove the Tray and the Foot Rail by reversing the installation procedure.

Leave the Foam Washer and the Aluminum Spacers in place. Screw in the Sealing Plugs, reusing the M6 Nyloc Nuts and Washers that held the Foot Rail in position.

5

COMPLETION

4.1

Congratulations! You did it. Take a step back and admire your work!



6

INSTALL OTHER VEHICLE AND RACK ACCESSORIES

Now's the time to visit your favorite Front Runner Dealer in person or online.

IMPORTANT!

FRONT RUNNER RACK KITS OFTEN HAVE A HIGHER LOAD RATING THAN THE VEHICLES THEY ARE MOUNTED TO. PLEASE REFER TO YOUR SPECIFIC VEHICLE MANUFACTURER FOR A RECOMMENDED ROOF RATING. FRONT RUNNER CANNOT BE RESPONSIBLE FOR IMPROPER LOADING BEYOND THE VEHICLE MANUFACTURER'S STATED LOAD CAPACITY.

Be sure to tag us. We love to see our gear in action! #FrontRunnerOutfitters #BornToRoam

Share your adventures on: 