



# Installation Instructions Fabric Replacement Top for Trektop NX

**Vehicle Application:**  
**Jeep Wrangler JK 2 Door**  
2007 – Current  
Part Number: 52822

## Installation Tips

Before you begin installing your new Trektop NX, please read all the instructions thoroughly.





### For a smooth fit:

For easier installation, the top should be installed at a temperature above 72° F. Below this temperature, the fabric may contract an inch or more, making it difficult to fit the vehicle.

It is normal for the fabric to contract and wrinkle when stored in the shipping carton. Within a few days after installation, the fabric will relax and the wrinkles will disappear.

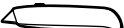

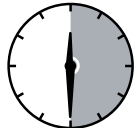
**CAUTION** Safety glasses should be worn at all times when installing this product.

Tools	Installation Time	Support
 Phillips Screwdriver  Utility Knife  Safety Glasses	 1/2 Hour  <b>Skill Level</b>   <b>2 - Moderately Easy</b>	<p>We're here to help! Go to <a href="http://www.Bestop.com">www.Bestop.com</a> and click "Contact Us"</p>  <p>See a video showing installation of this top at <a href="http://www.bestop.com/video">www.bestop.com/video</a></p>



**WARNING** This product is designed primarily to enhance the appearance of the vehicle and to shield the occupants from ordinary weather conditions. Do not rely in any way on the components of this product to contain the occupants within the vehicle, or to protect against injury or death in the event of an accident. This product will not protect the occupants from falling objects. Never operate the vehicle in excess of manufacturer's specifications.

### WEAR SEAT BELTS AT ALL TIMES

Read and follow, precisely, all installation instructions provided when installing this product. Failure to do so may result in a poor fit and could place occupants of the vehicle in a potentially dangerous situation.



## Installation Instructions Fabric Replacement Top for Trektop NX

Vehicle Application:  
Jeep Wrangler JK 2 Door  
2007 – Current  
Part Number: 52822

### Sugerencias de Instalación

**Antes de empezar a instalar esta unidad, lea atentamente todas las instrucciones.**

#### Para un buen ajuste:

Para facilitar la instalación, el producto debe instalarse a temperaturas superiores a 72 °F (22 °C).

Por debajo de esta temperatura, la tela puede encogerse una pulgada o más, lo que dificultaría su ajuste al vehículo.

Es normal que la tela se contraiga o arrugue cuando está guardada en la caja de empaque. A los pocos días después de la instalación, la tela se relajará y las arrugas desaparecerán.



#### ADVERTENCIA

Este producto se diseñó principalmente para mejorar la apariencia del vehículo y proteger a los ocupantes de las condiciones climáticas comunes. De ninguna manera piense que los componentes de este producto pueden servir como medio de contención para los ocupantes del vehículo o que pueden protegerlos contra lesiones o la muerte en caso de accidente. Este producto no protegerá a los ocupantes contra caídas de objetos. Nunca conduzca este vehículo fuera de las especificaciones del fabricante.

#### USE LOS CINTURONES DE SEGURIDAD EN TODO MOMENTO

Lea y siga con precisión todas las instrucciones de instalación que se proporcionan para instalar este producto. Si no lo hace, podría producirse un mal ajuste que colocaría a los ocupantes del vehículo en una situación potencialmente peligrosa.



#### PRECAUCIÓN

Debe usar gafas protectoras en todo momento durante la instalación de este producto.

### Conseils pour l'installation

**Lire toutes les instructions au complet avant de commencer l'installation de cet assemblage.**

#### Pour un ajustement sans problème :

Afin de faciliter l'installation, ce produit doit être installé à des températures au-dessus de 72 °F (22 °C).

Sous cette température, le tissu peut rétrécir d'un pouce (2,5 cm) ou plus, ce qui rendra l'ajustement sur le véhicule difficile.

Il est normal que le tissu rétrécisse et plisse pendant qu'il est dans la boîte d'expédition. En quelques jours après l'installation, le tissu se détendra et les plis disparaîtront.



#### AVERTISSEMENT

Ce produit est conçu principalement pour améliorer l'apparence du véhicule et pour protéger les occupants des conditions météorologiques usuelles. Ne jamais se fier aux composants de ce produit pour se protéger de blessures ou de la mort en cas d'accident. Ce produit ne protégera pas les occupants des chutes d'objets. Ne jamais utiliser le véhicule au-delà des caractéristiques techniques indiquées par le fabricant.

#### PORTER UNE CEINTURE DE SÉCURITÉ EN TOUT TEMPS

Lire et suivre, très fidèlement, toutes les instructions d'installation fournies lors de l'installation de ce produit. Ne pas suivre cette consigne peut causer une installation inadéquate et mettre les occupants du véhicule dans une situation potentiellement dangereuse.



#### MISE EN GARDE

Des lunettes de sécurité doivent être portées en tout temps lors de l'installation de ce produit.



**Installation Instructions**  
**Fabric Replacement Top for Trektop NX**

**Vehicle Application:**  
**Jeep Wrangler JK 2 Door**  
2007 – Current  
Part Number: 52822



**!STOP! Do not proceed unless you have a Trektop NX already installed.**  
**You will need these parts to complete the installation**

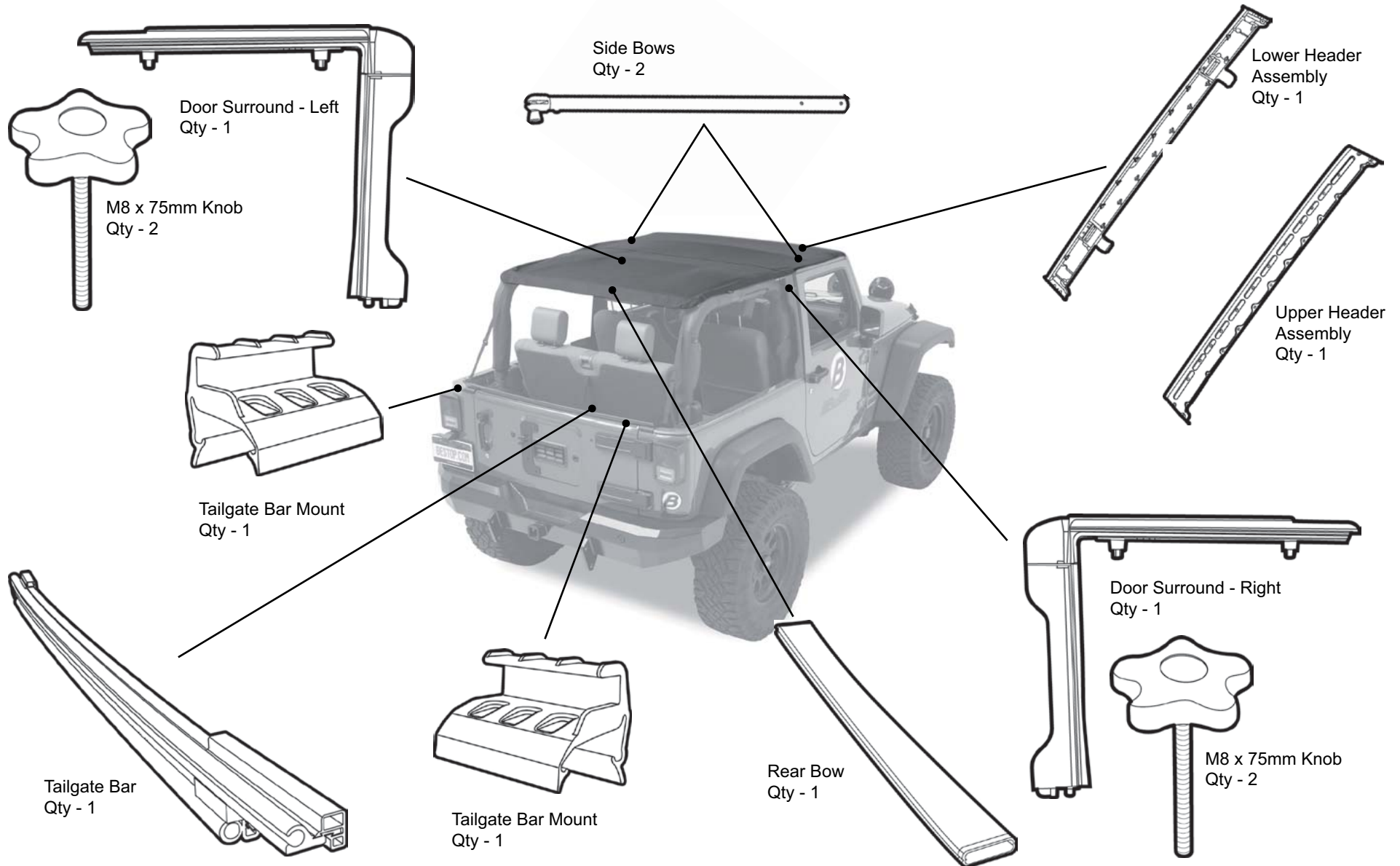



## Parts List

- Required parts for each installation section - Page number in Installation Guide

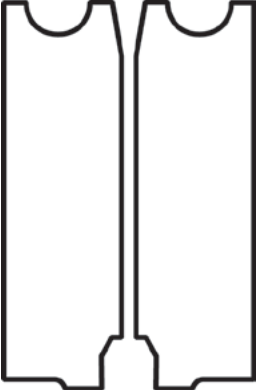
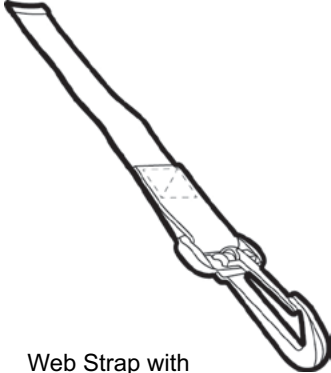
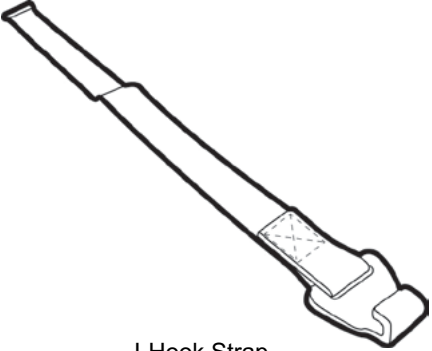
Sections 7, 12 & 13		Foam Strips and Straps	Pages 13, 18 & 19 of Guide
			
Foam Tape Strips Qty - 2 Part # 417.43	Foam Seals Qty - 1 per side Part # 457.76 (R) & 457.77 (L)	Web Strap with Snap Hook Qty - 2 Part # 460.37	J-Hook Strap Qty - 2 Part # 486.94

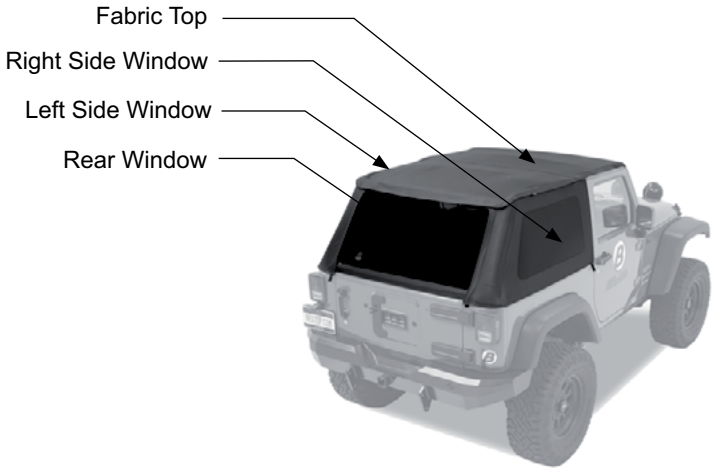
Section 5 – 19	Fabric Top and Windows	Pages 10 – 26 of Guide
		

Step 1

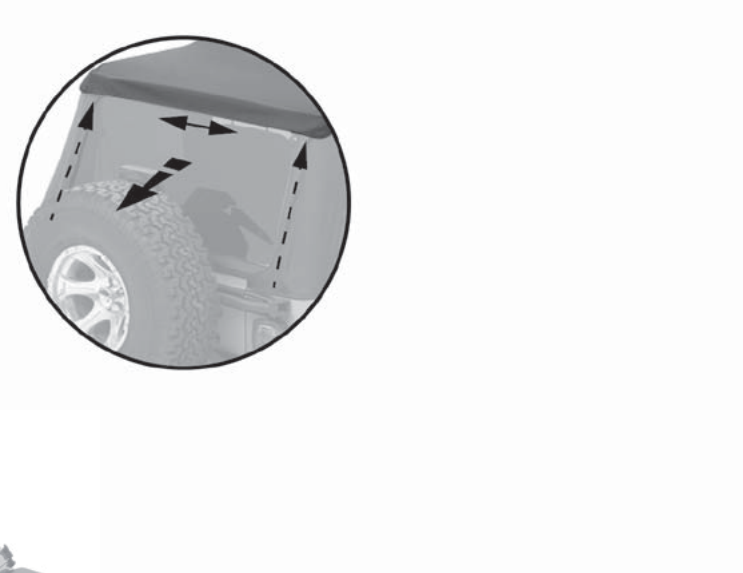
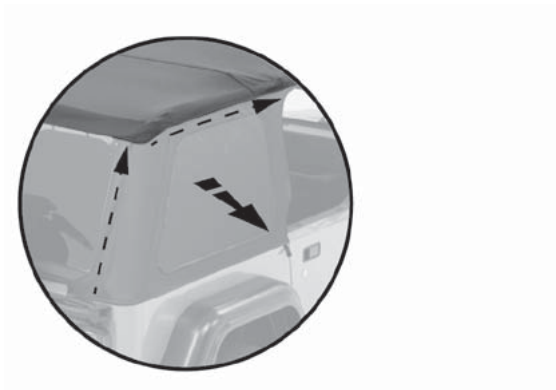

Step 1

Remove Side Windows and Rear Window.



Step 1

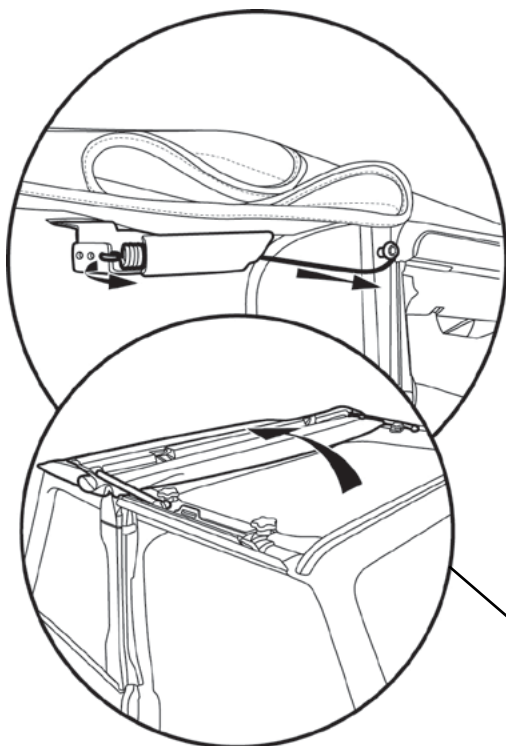

Step 1

Open the Header Back towards the rear of the Jeep to relax tension on the cable. Unhook the cable spring from the cable bracket on both sides.

Make sure the cable is not caught on the Door Surround Screw.

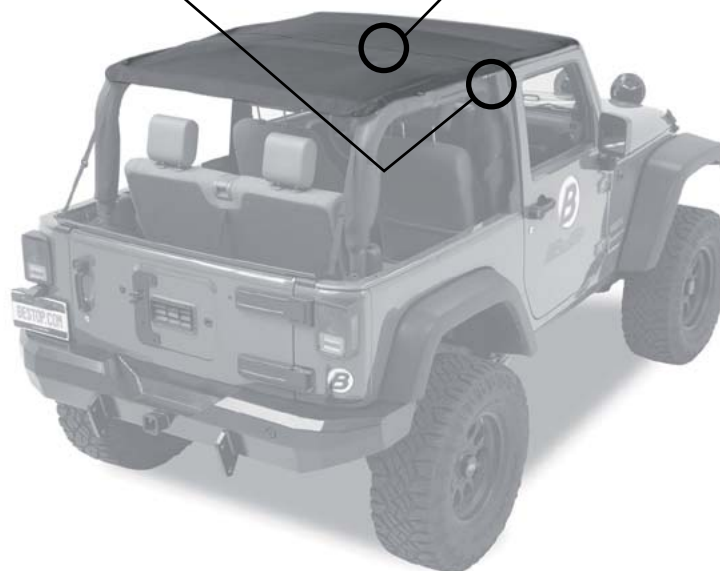

Step 2

Loosen the Center Straps and unhook them from the underside of the Sport Bar.

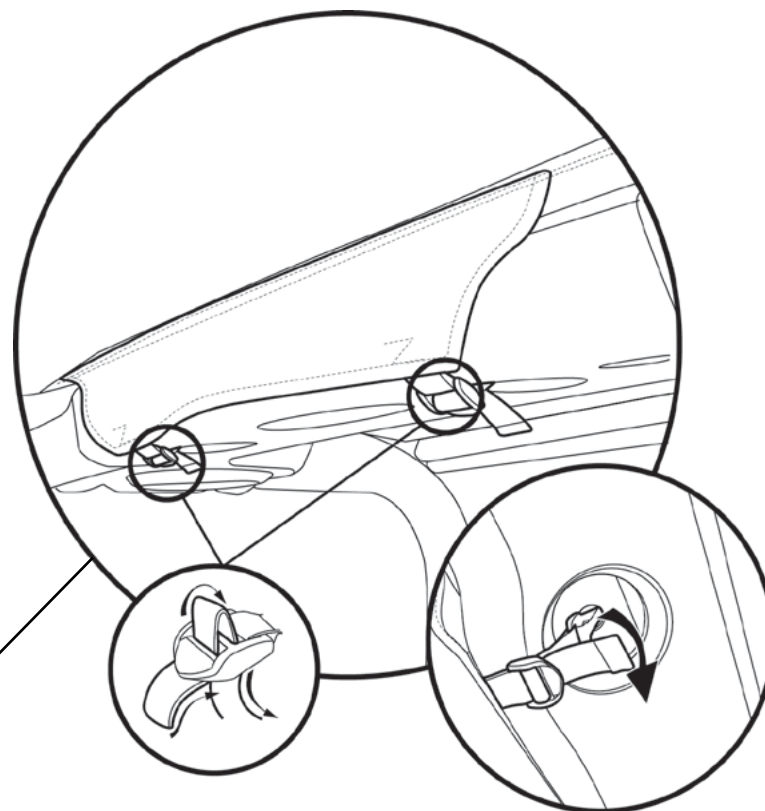

Step 3

Step 4

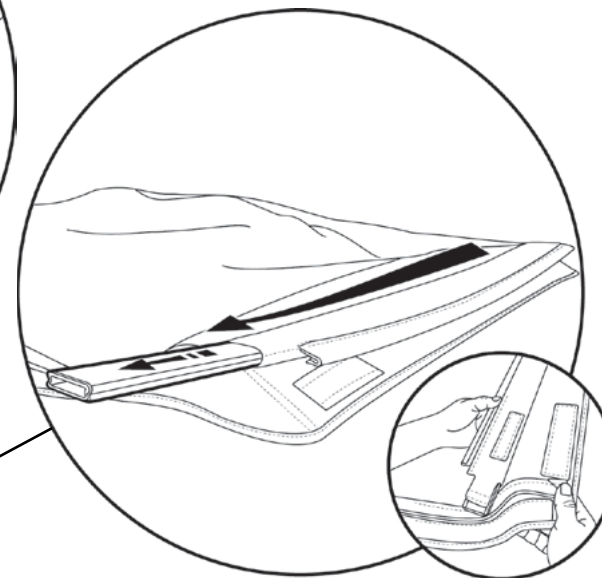
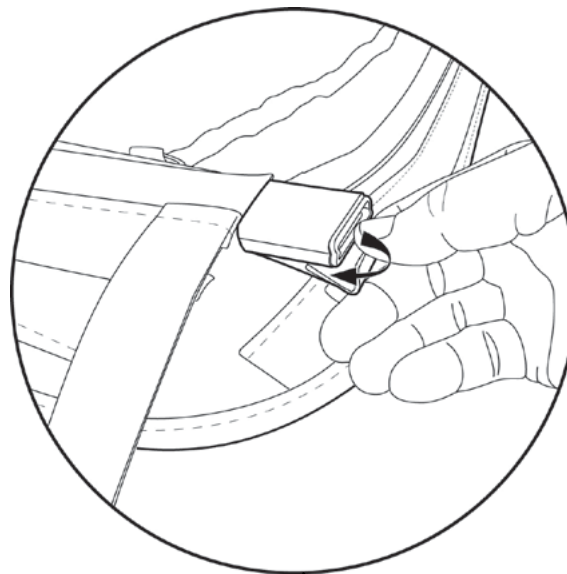
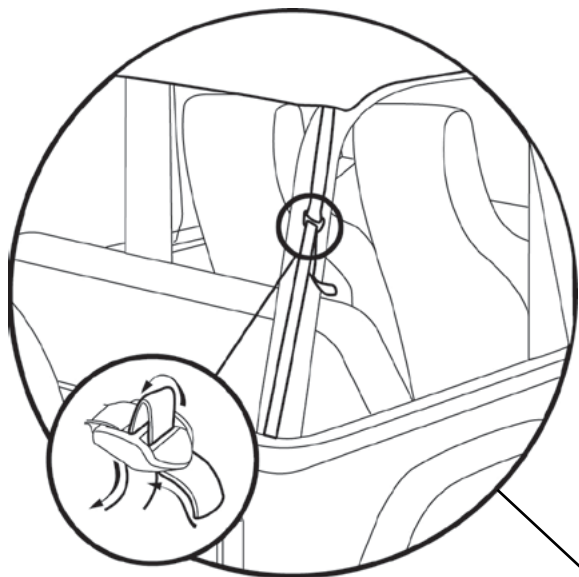

Step 3

Loosen, remove, and discard Rear Strap.

Step 4

Release the J-Hooks on the rear bow flaps from the ends of the Rear Bow. Slide the Rear Bow out of the pocket in the Top Fabric.

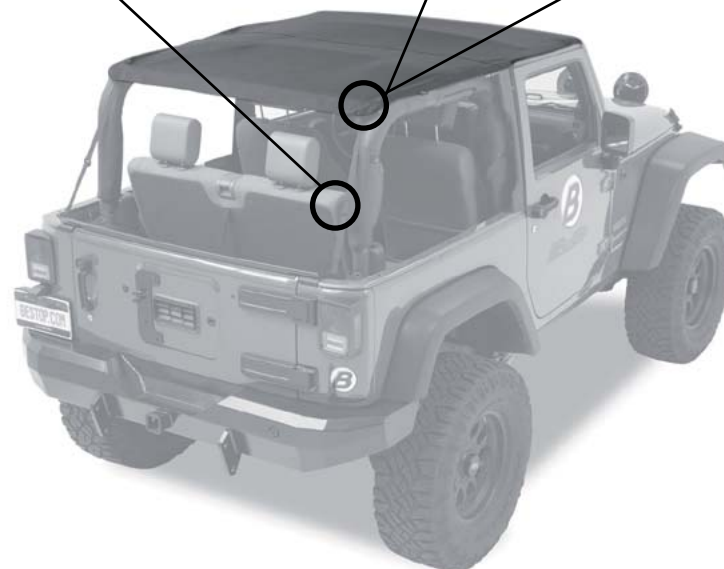

**Step 1**

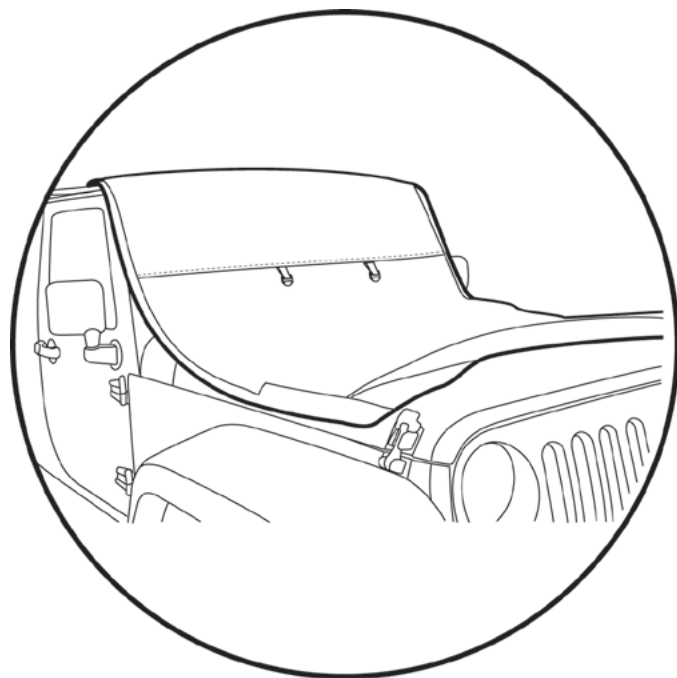

**Step 2**

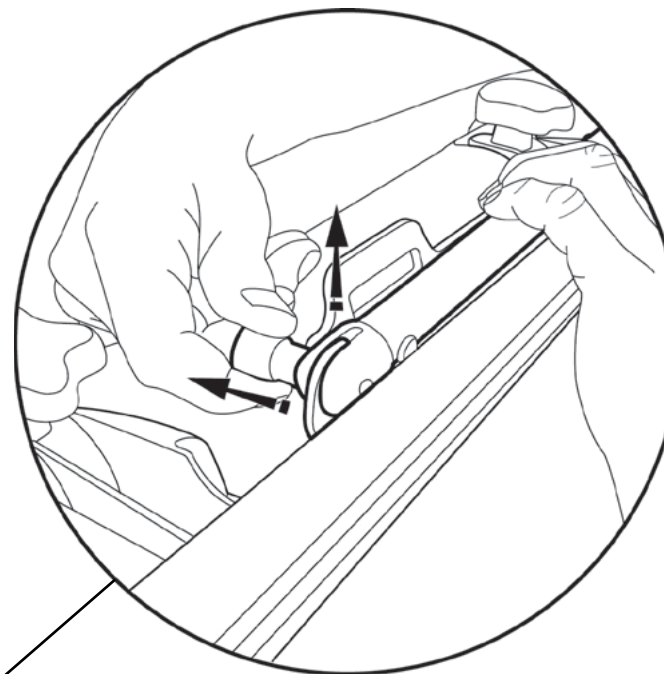

**Step 1**

Fold the Top Fabric toward the front of the Header.



**Step 2**

Pull back on the Quick Release Knob on the Side Bow and remove from the Bow Bracket on both sides of the vehicle. Remove the header and fabric from the vehicle.



Step 1

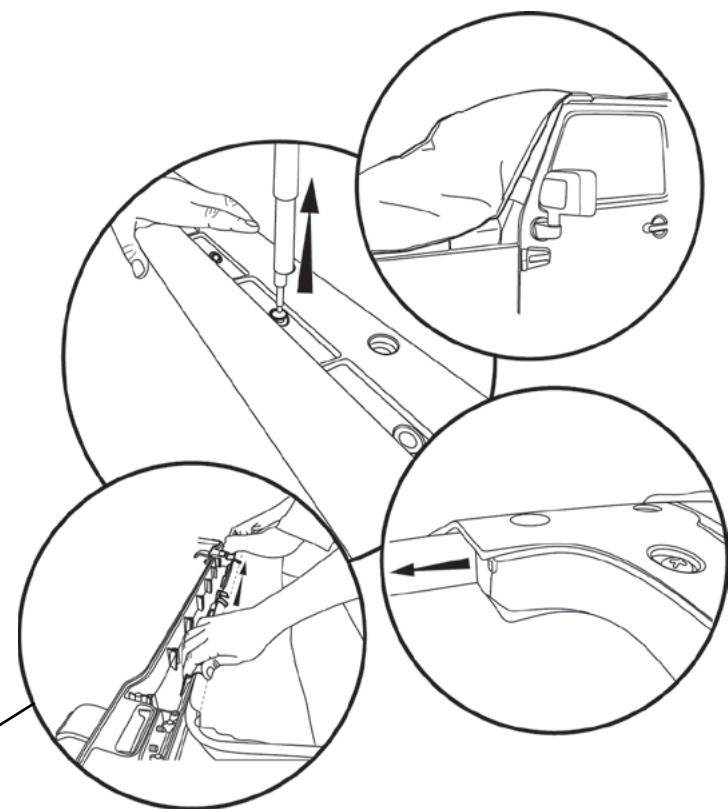
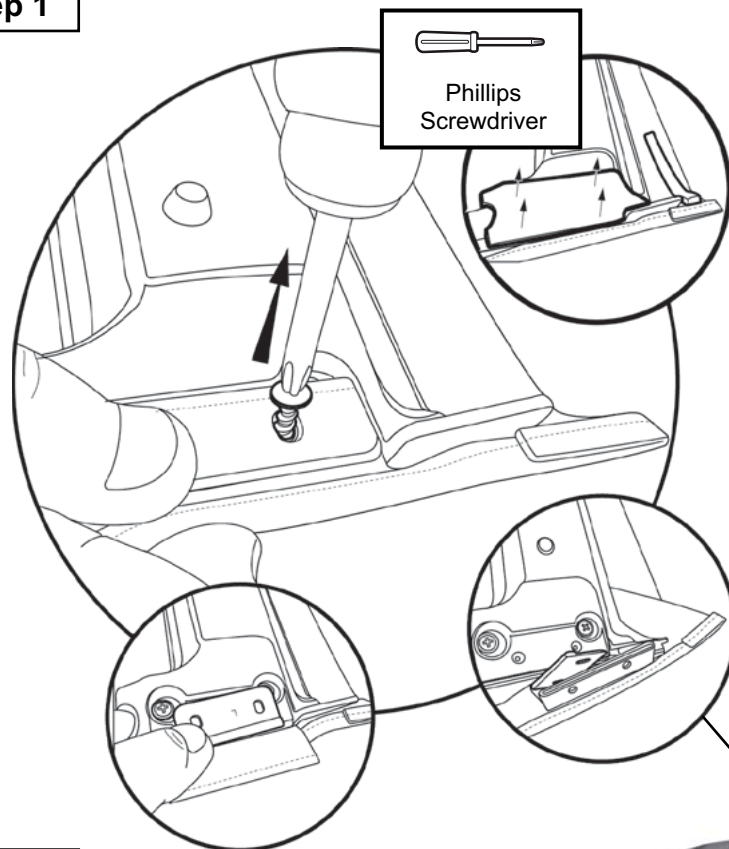

Step 1

Remove the Foam Seals. Use a phillips screwdriver to remove the two screws that secure the fabric to the header.  
**Set the screws aside to be reused later.**

NOTE

This will loosen the side bow also. You can remove the bows and reinstall them later or place the screws back in to hold the bow in place until later.

Step 2

Drape the fabric over the header to expose the screws that secure the fabric to the upper and lower headers. Remove all screws. **Set the screws aside for use in installing the new top.**

Remove the fabric along the front edge of the top out of the channel in the lower header.



Step 1 Top Fabric

Step 2

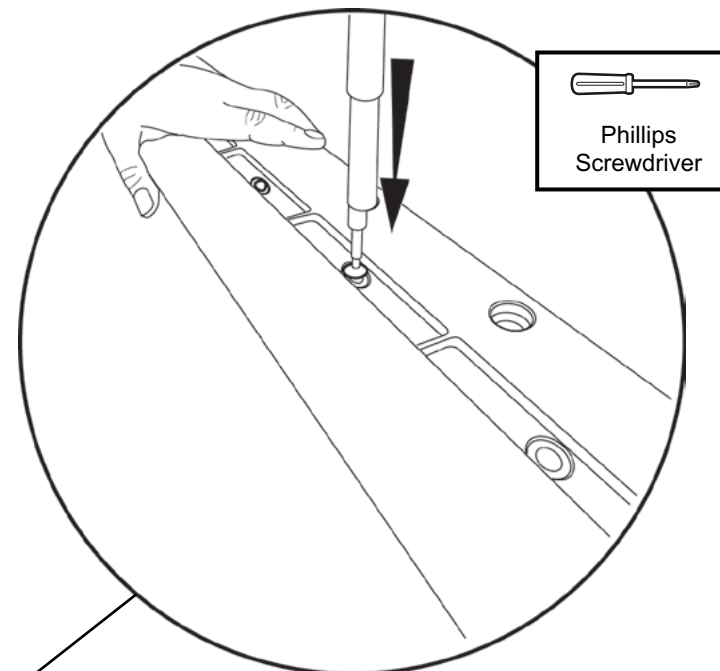
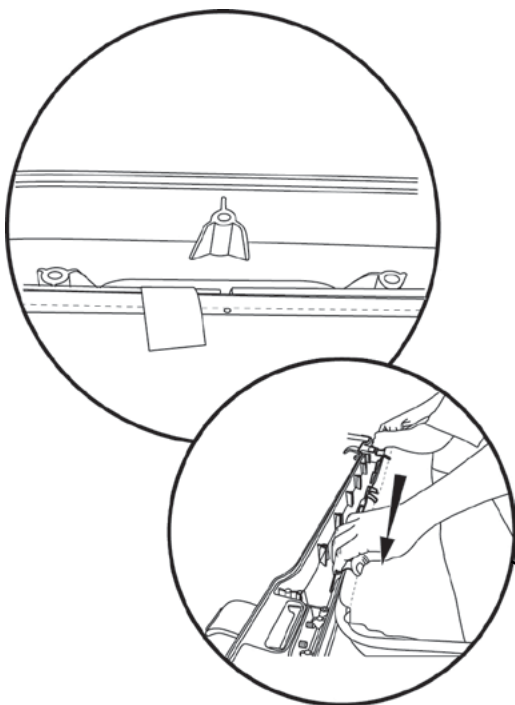

Step 1

Lay the Lower Header on the ground and position the Sprint Top fabric in the same position as the original top that was removed.  
 Install the extrusion along the front of the fabric into the header channel.  
 Center the fabric and use masking tape to hold it in position.

Step 2

Place the Upper Header onto the Lower Header assembly and reinstall the screws removed in section 4.



Step 1

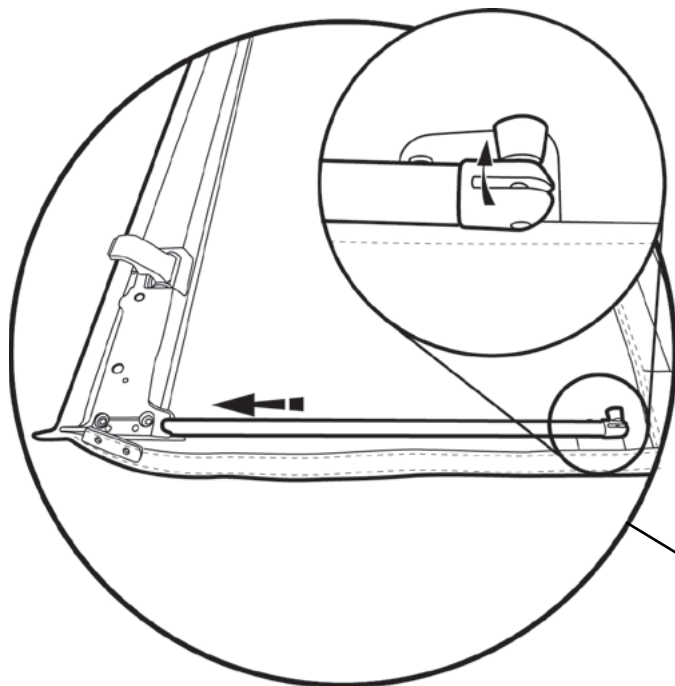

Step 2

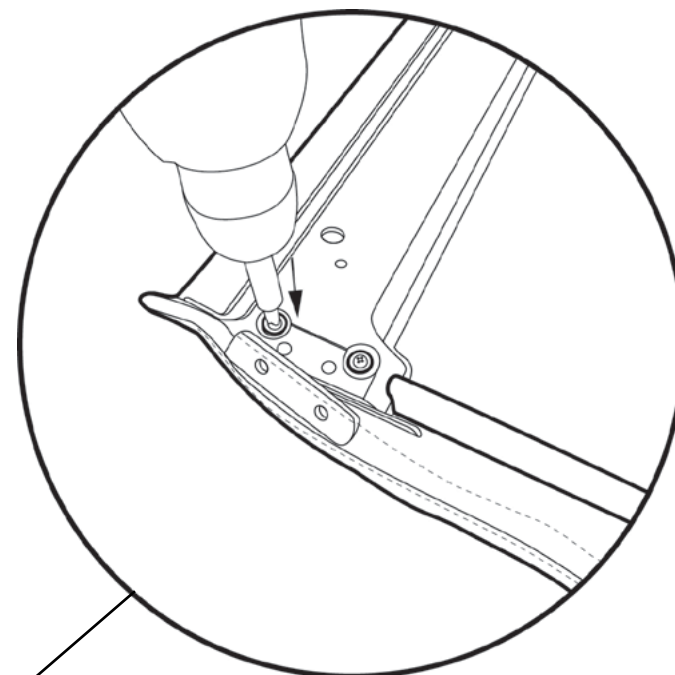

Step 1

Insert Side Bows into Header Assembly on each side.

**Pivot quick release knobs to face toward inside of assembly.**



Step 2

Re-use the original #8 x 1/2" Screws removed in section 4 to mount a Side Bow to each side of the Header Assembly.

Step 3

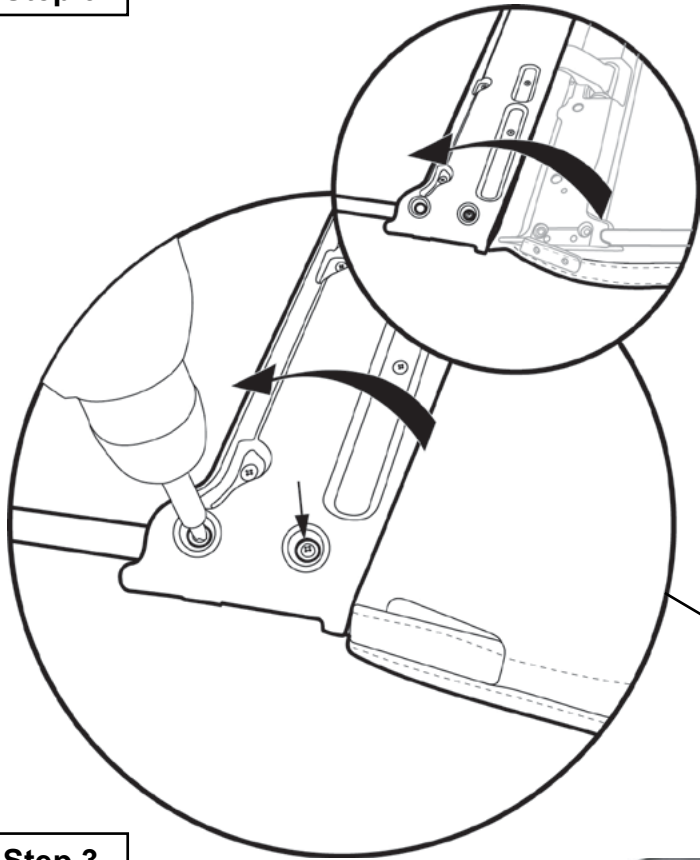

Step 3

Rotate the Header Assembly and re-use the original #8 x 1/2" Screws removed in section 2 to complete the side bow install.

Step 4

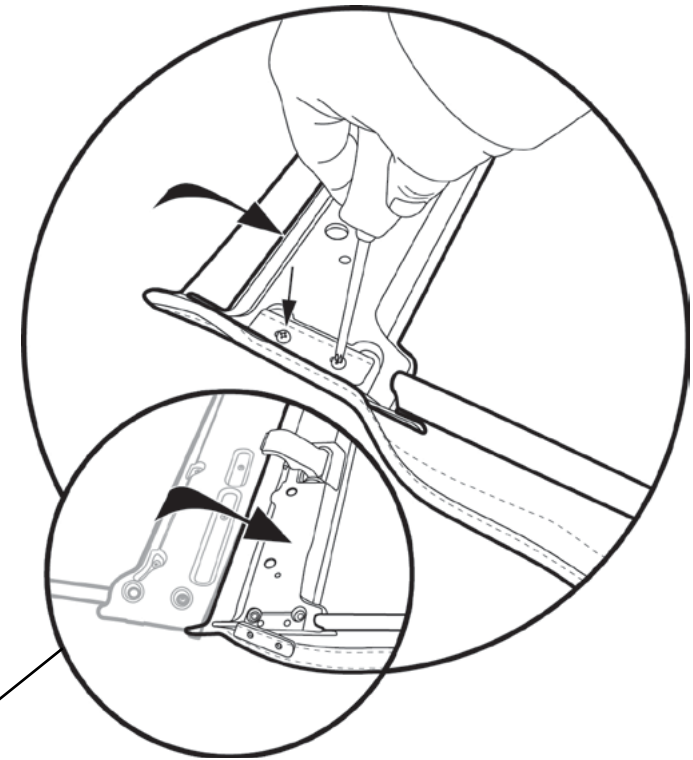

Step 4

Rotate the Header Assembly back into position and re-use the screws removed in section 2.



Step 1 417.43 457.76

Hardware

Step 2

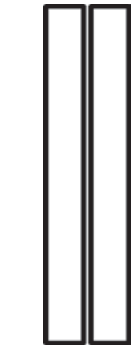
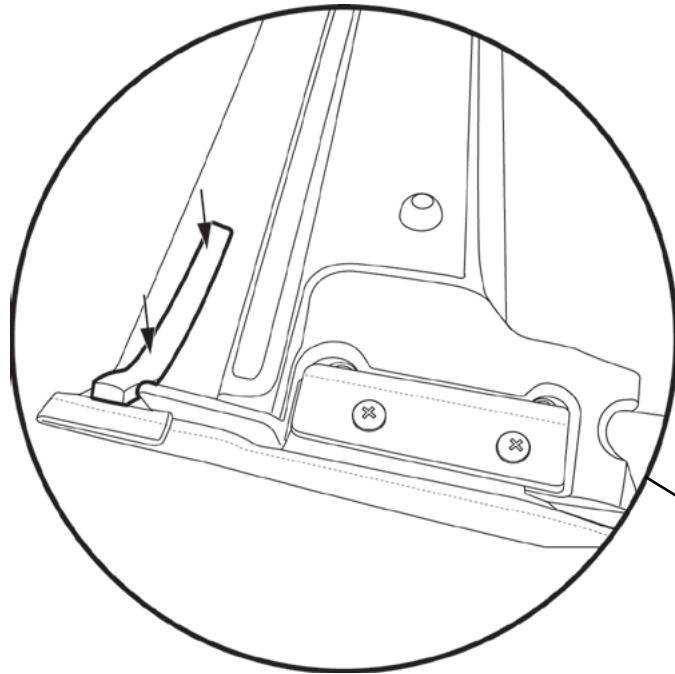

Foam Tape Strips  
Qty - 1 per side  
Part # 417.43

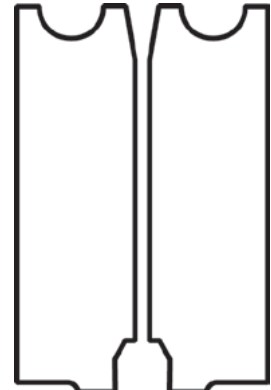

Foam Seals  
Qty - 1 per side  
Part # 457.76 (R) &  
457.77 (L)

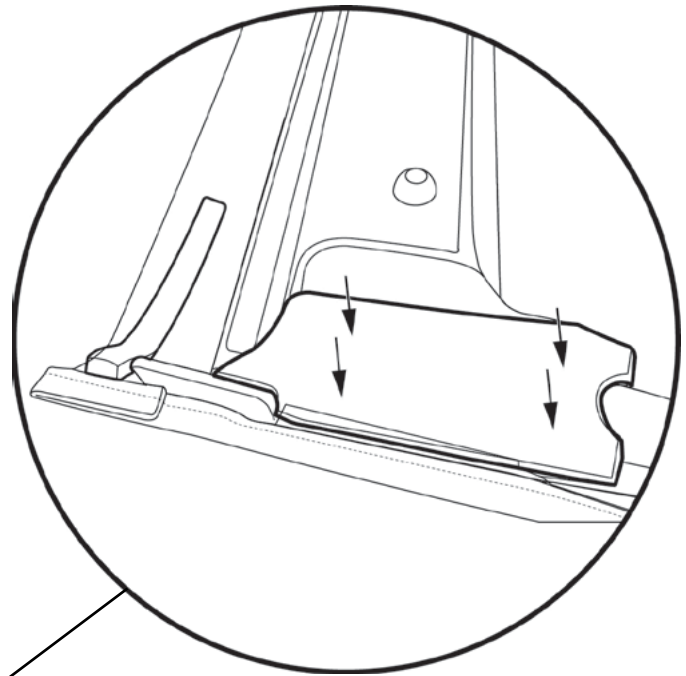

Step 1

Peel the backing off the Foam Tape Strips and install them on each side of the Header.

Step 2

Peel the backing off the Foam Seal and install it on the passenger side of the Header. Repeat on the driver side.



**Step 1**

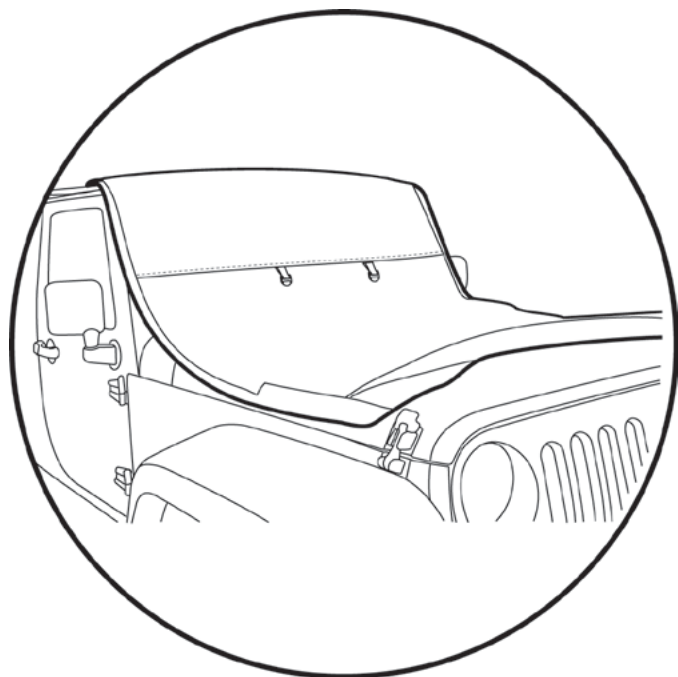

**Step 2**

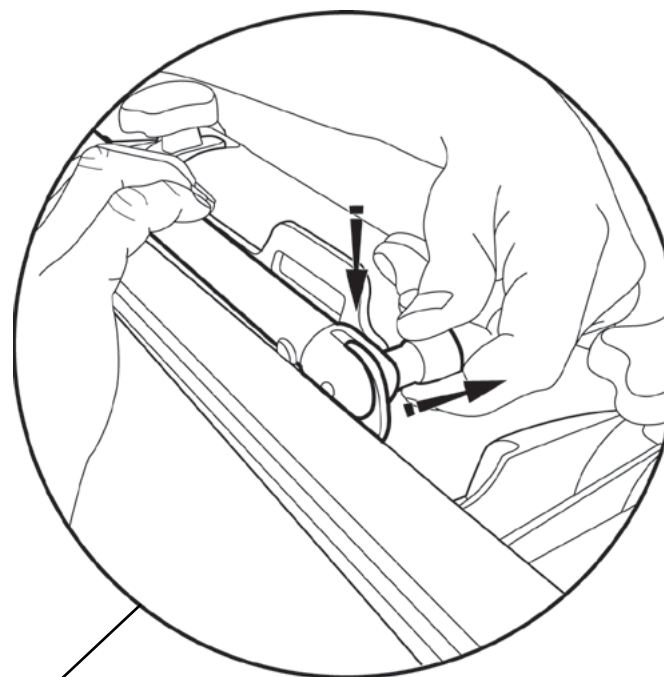

**Step 1**

Fold the Top Fabric toward the front of the Header. Place the Header Assembly on vehicle, with the backing up and the Side Bows on top of the Door Surrounds.



**Step 2**

Pull back on the Quick Release Knob on the Side Bow and secure to the Quick Release Bracket on both sides of the vehicle. The spring pin should install all the way into the pivot when complete.

**Step 1**

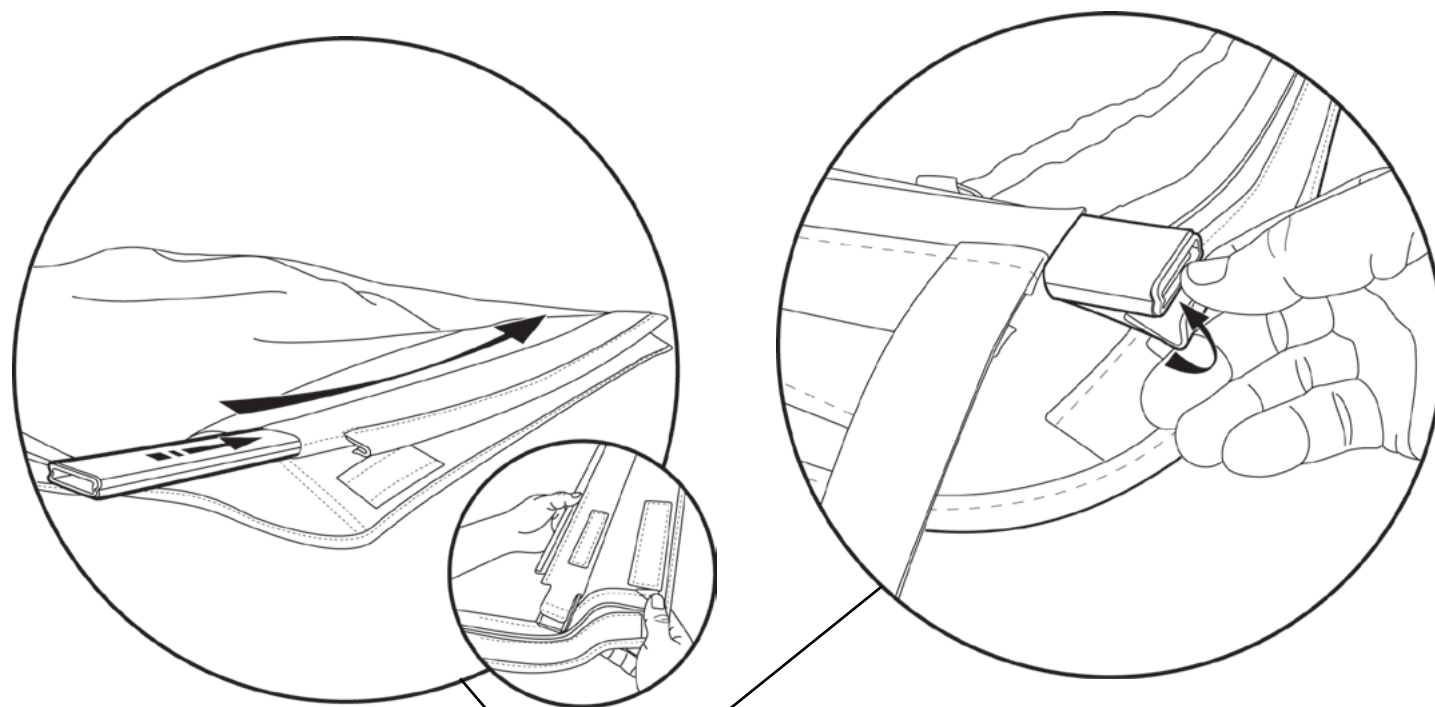

**Step 1**

Slide the Rear Bow into the pocket inside the rear of the Top Fabric. Secure the J-Hooks on the rear bow flaps to the ends of the Rear Bow.

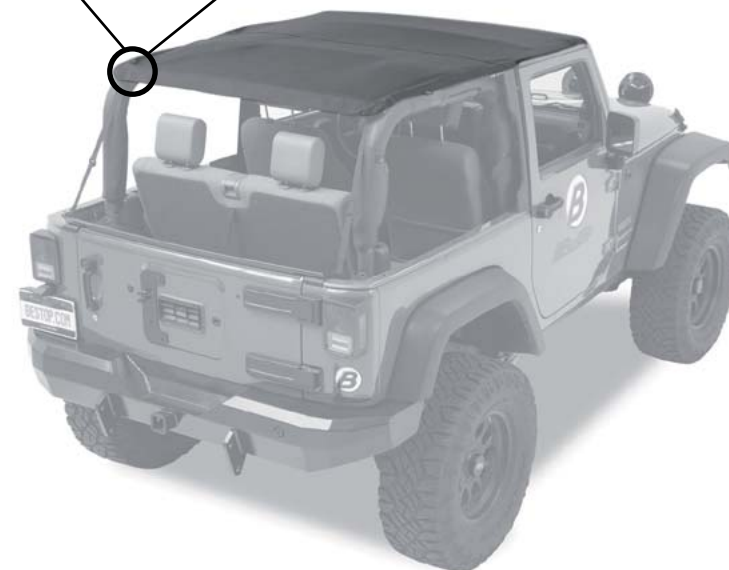

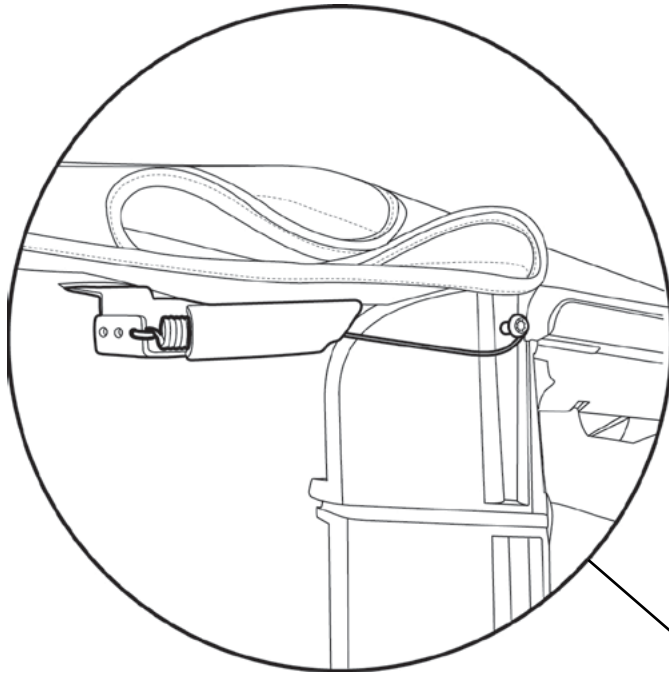
**Step 1****Step 1**

Open the Header back toward the rear of the Jeep. Run the cable under the Door Surround screw and through the Cable Bracket. Hook the cable spring to the outer hole on the bracket.

To increase spring tension for a tighter fit, hook the spring into one of the inner holes in the Cable Bracket.





**Step 1**

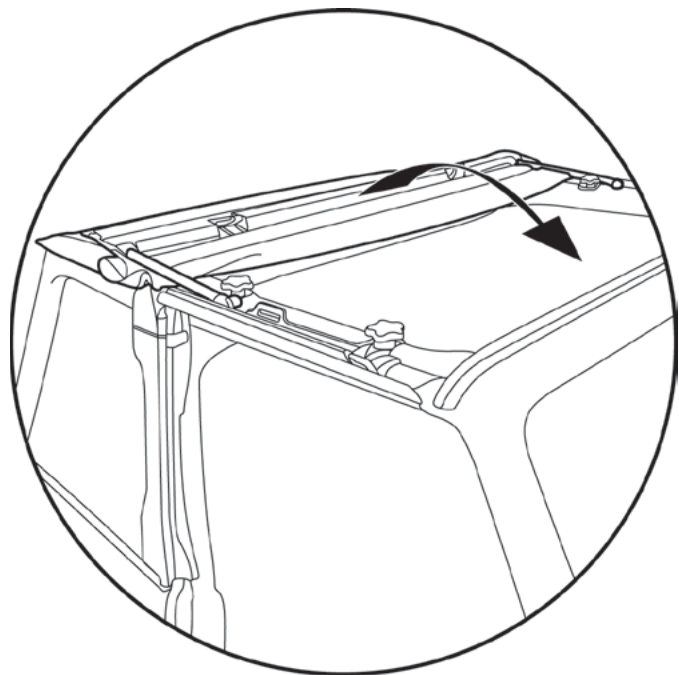

**Step 2**

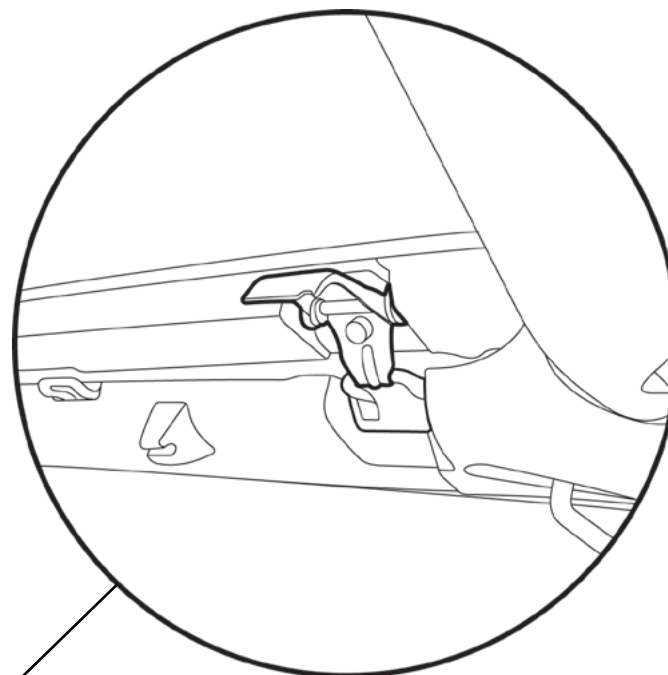

**Step 1**

Close Sunrider.



**Step 2**

Hook the latches on the Header into the loops in the windshield.  
Repeat on opposite side.

Step 1 460.37

Hardware

Web Strap with  
Snap Hook  
Qty - 2  
Part # 460.37

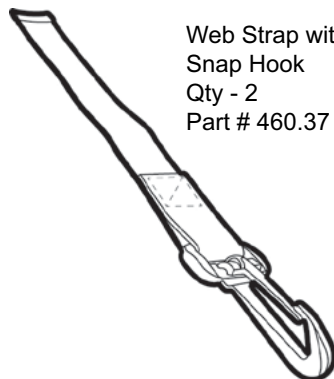
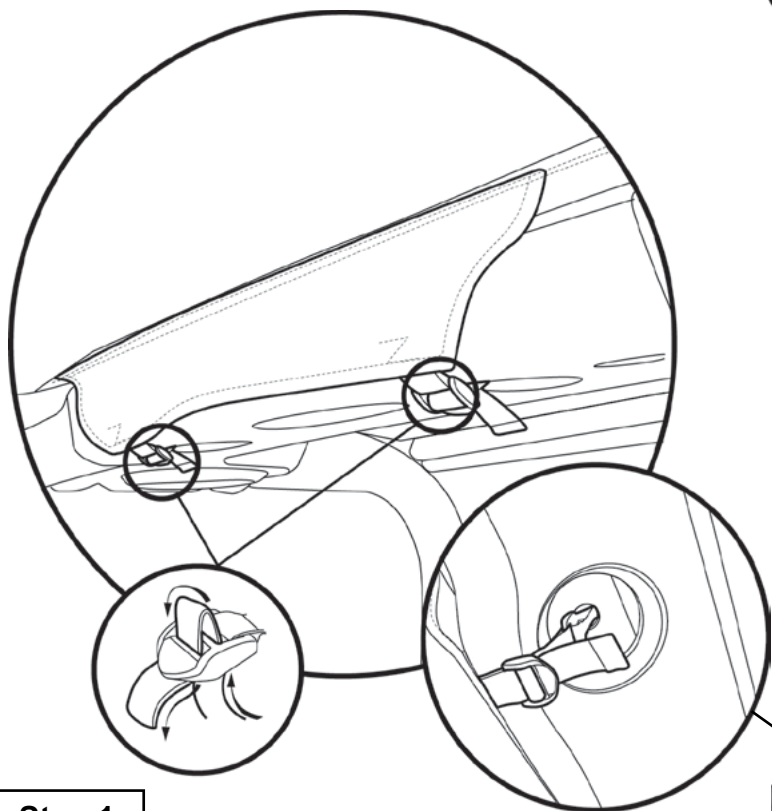

Step 1

Thread a Web Strap with Snap Hook through each buckle. Hook the straps into the slot on the underside of the sportbar. Pull the ends of each strap to tighten securely.



**Step 1** 486.94

**Hardware**

**Step 2**

J-Hook Strap  
Qty - 1 ea. side  
Part # 486.94

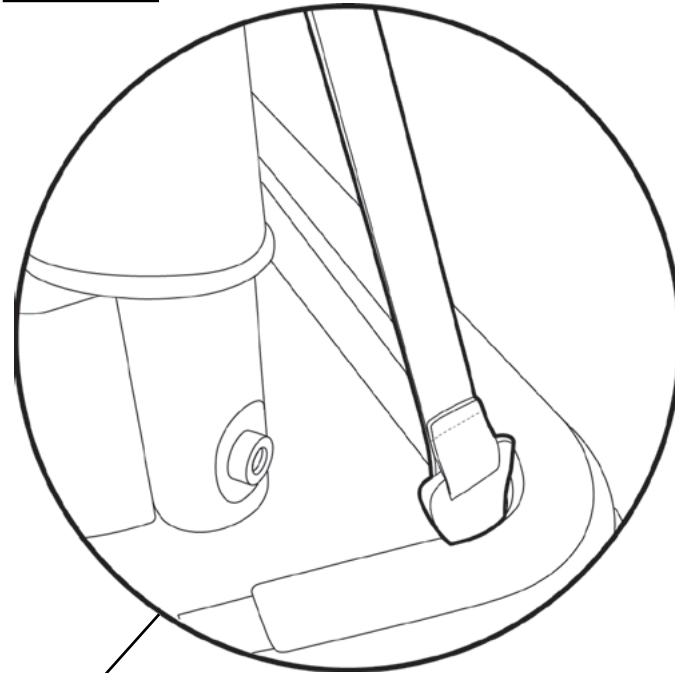
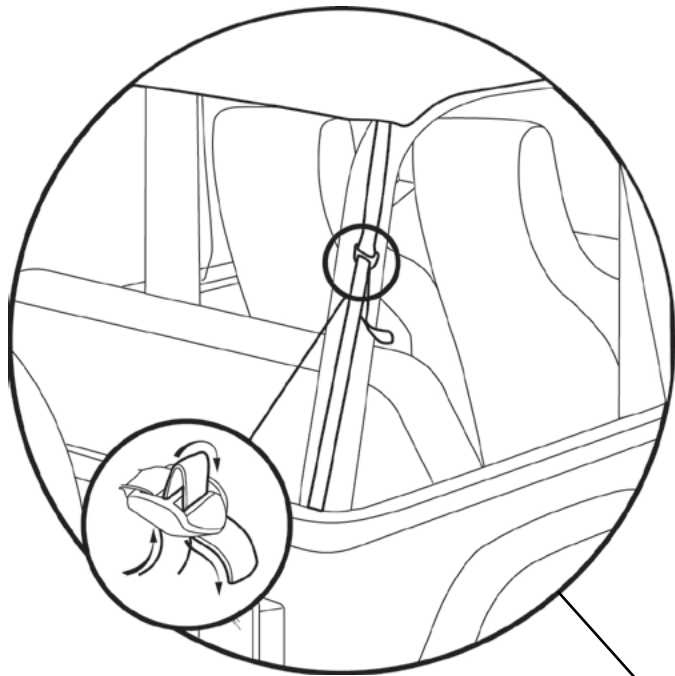

**Step 1**

Thread a J-Hook Buckle Strap through the buckle on one of the rear straps.

**Step 2**

Hook the strap to the ledge inside the rear corner of the vehicle. Repeat on both sides of the vehicle.

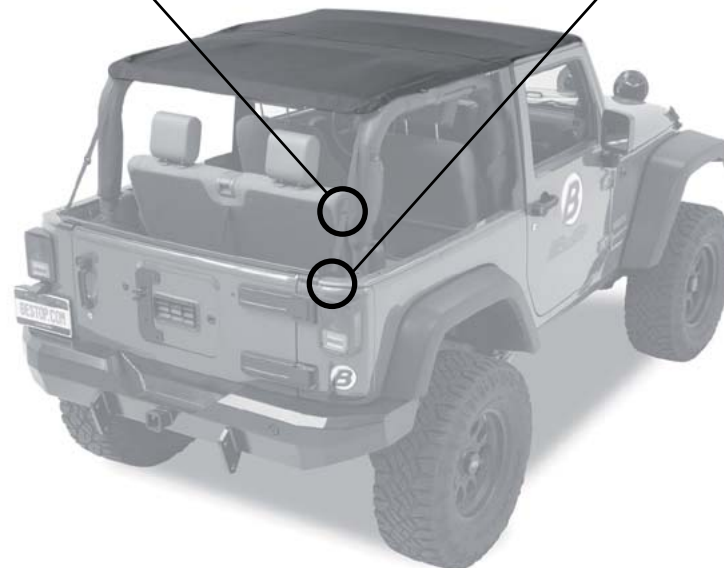

**Step 1**

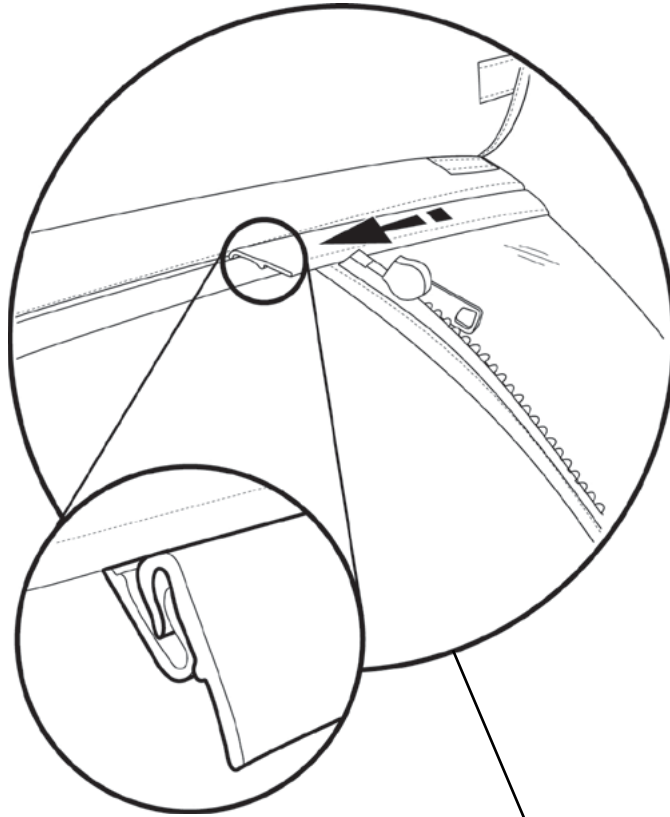

**Step 1**

Align the J-slide with the J-slide sewn into the rear of the Top. Slide them together until the Rear Window is centered in the opening.



Step 2

Step 1

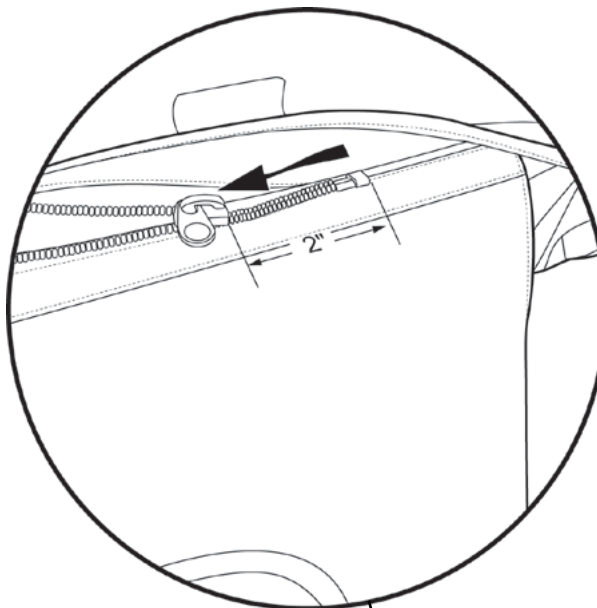
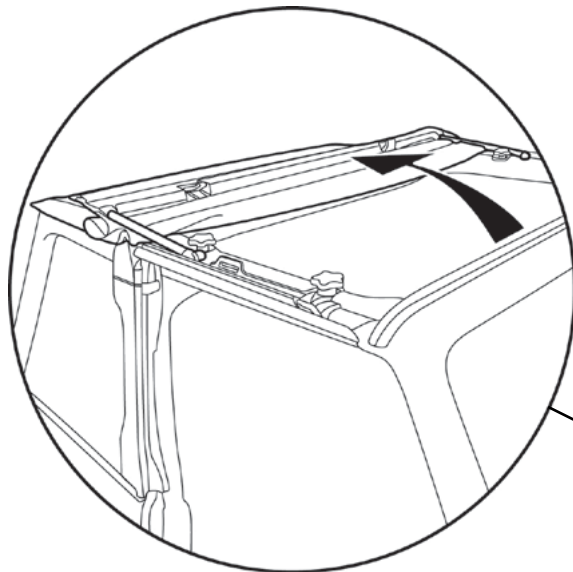

Step 3

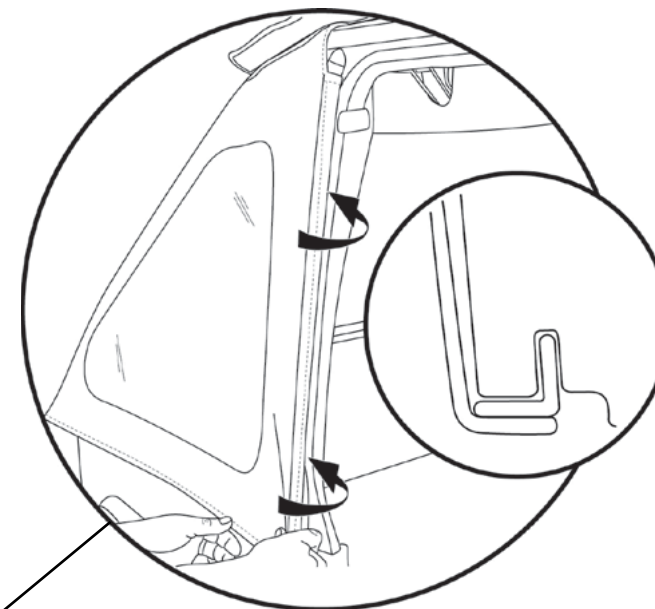

Step 1

Start the zipper along the top of the Side Window with the zipper in the Top. Only close the zipper 1-2".

Step 2

Start the zipper along the top of the Side Window with the zipper in the Top. Only close the zipper 1-2".

Step 3

Slip the plastic strip on the front of a Side Window into the channel in the Door Surround. Repeat with both Side Windows.



Step 4

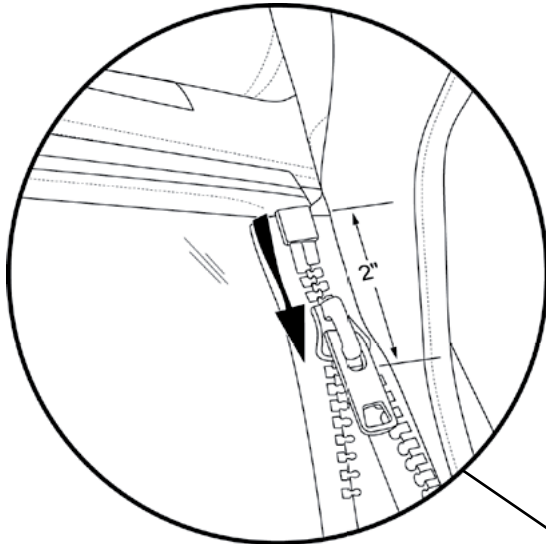

Step 5

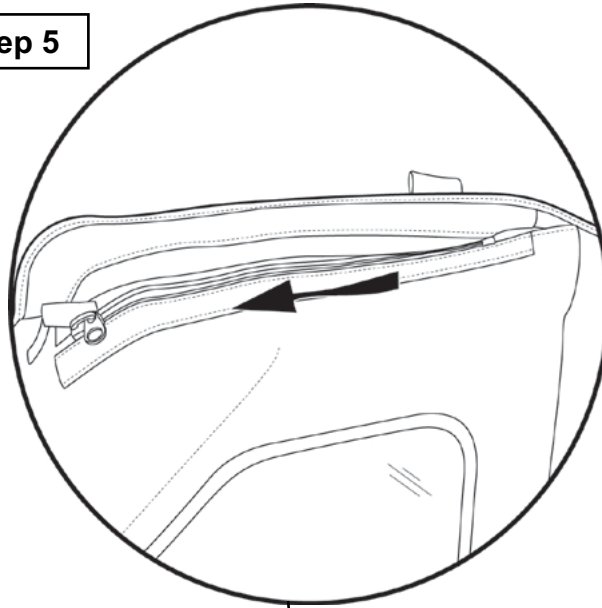

Step 6

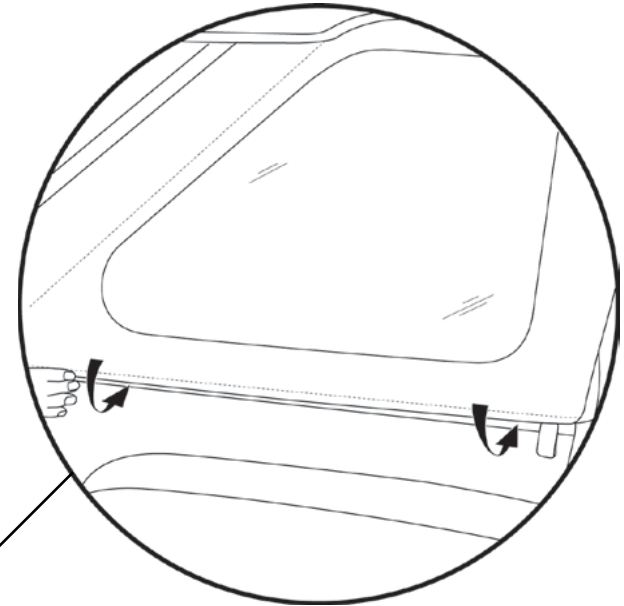

Step 4

Engage the Rear Window zipper with the Quarter Panel zipper. Only close the zipper 1-2".

Repeat on opposite side

Step 5

Close the zippers along the top of each Side Window..

Step 6

Slip the plastic strip along the bottom of the Side Windows into the channel in the belt rail on each side of the vehicle.

Repeat on opposite side.

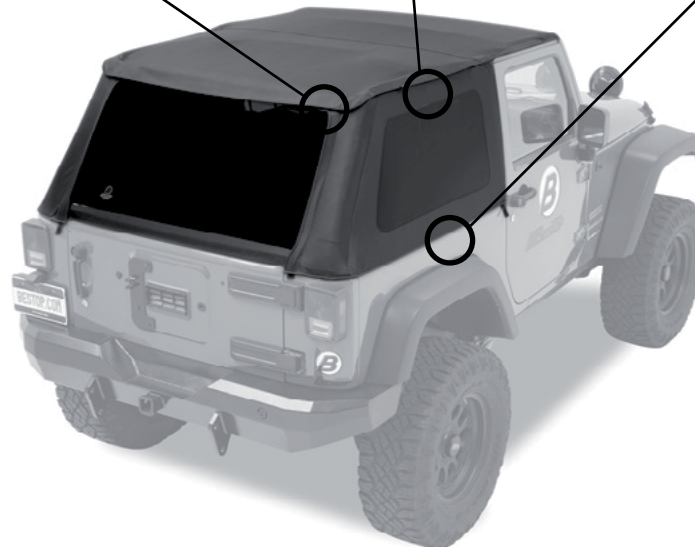

Step 1

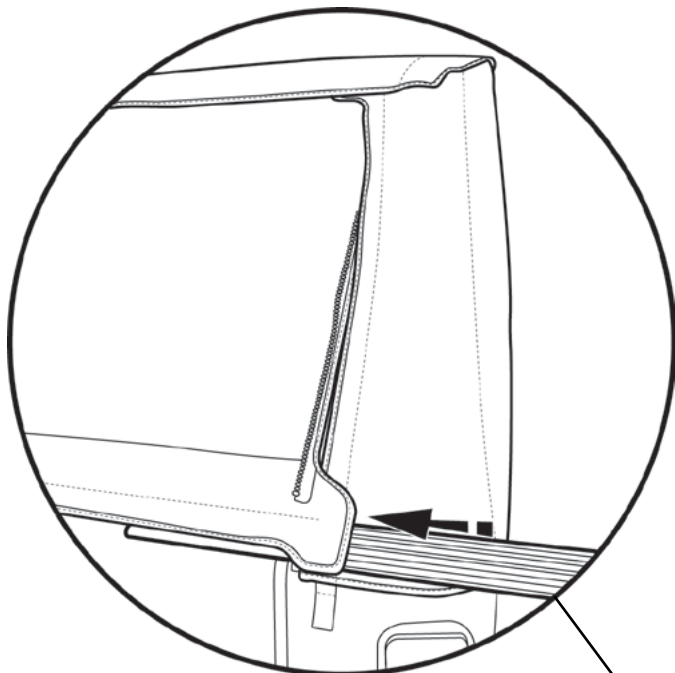

Hardware

Tailgate Bar  
Qty - 1  
Required, but not  
included

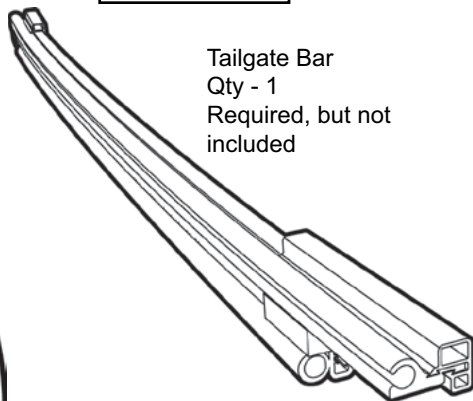

Step 2

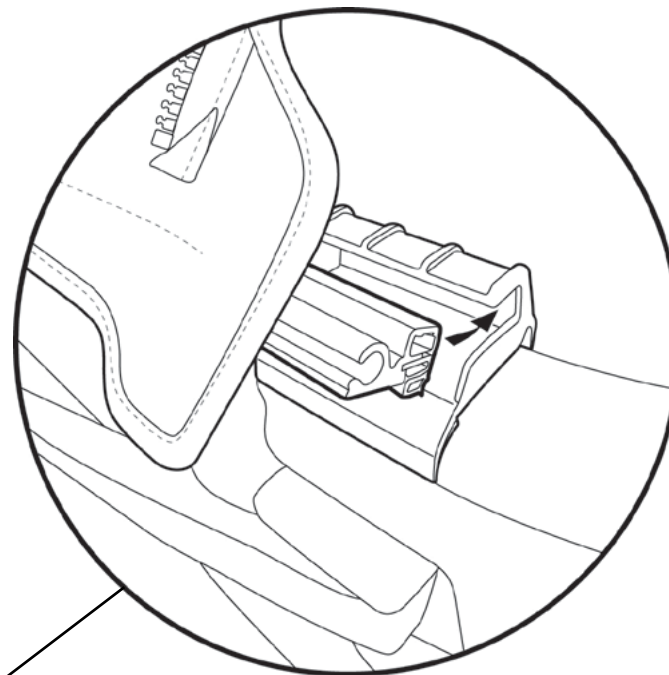

Step 1

Slide the channel in the Tailgate Bar onto the tubing along the bottom of the Rear Window on the inside.

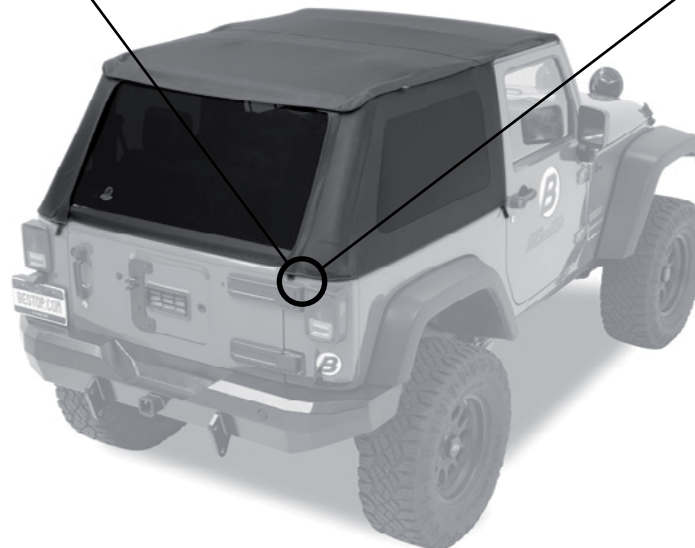

Step 2

Slide the Tailgate Bar into the Tailgate Bar Mounts on each side of the tailgate opening.

**Step 1**

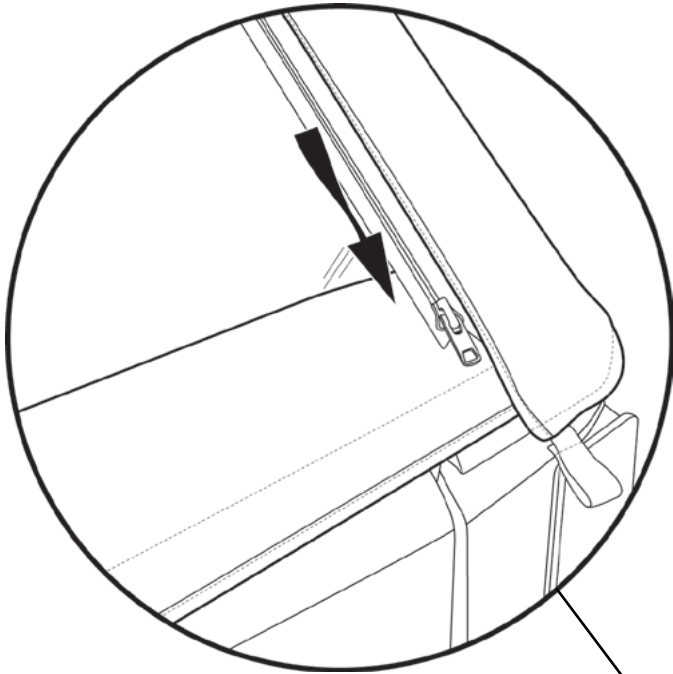

**Step 2**

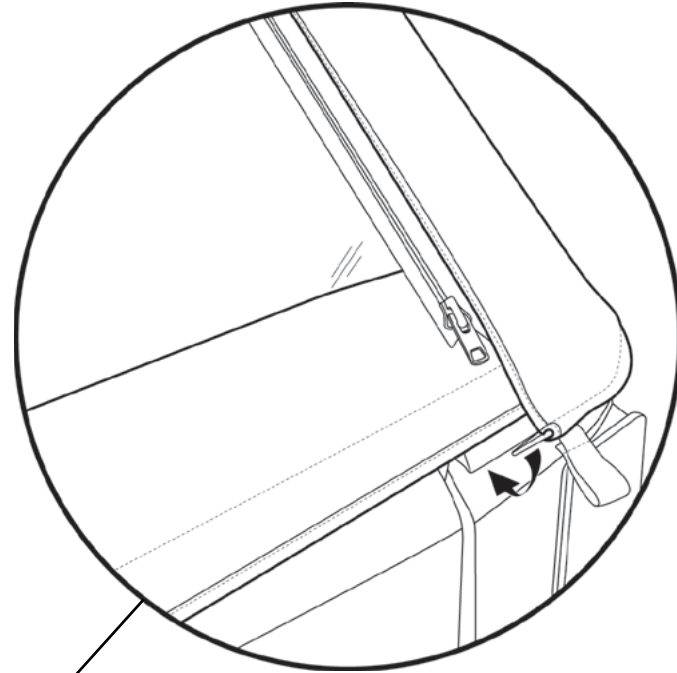

**Step 1**

Close the zippers on both sides of the Rear Window.

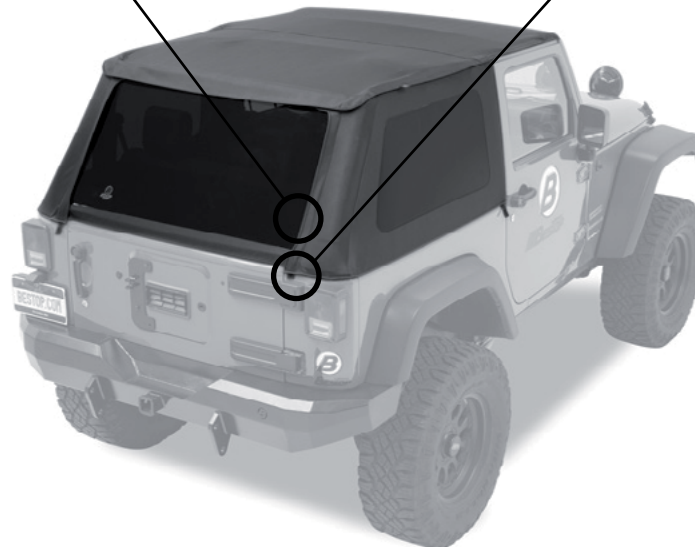

**Step 2**

Wrap the Side Windows over the Rear Window and slip the plastic strips on each Side Window under the Tailgate Bar Mounts on each side of the tailgate.



**Step 1**

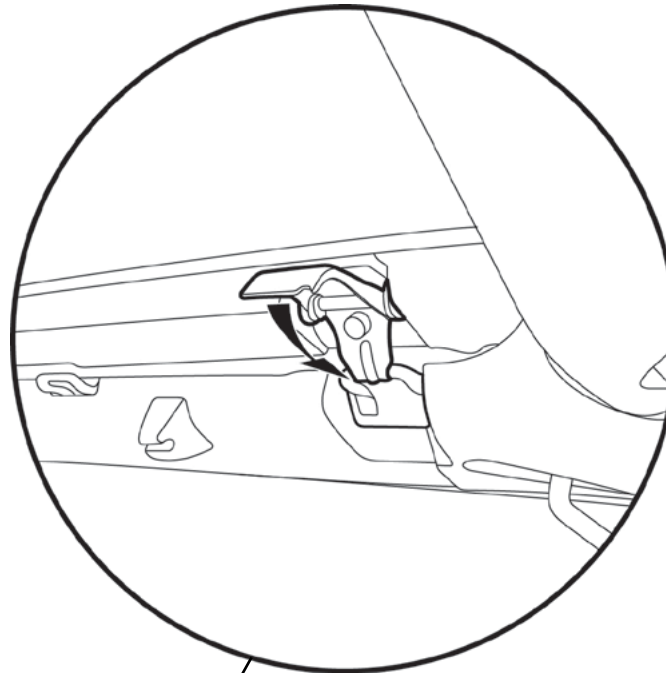
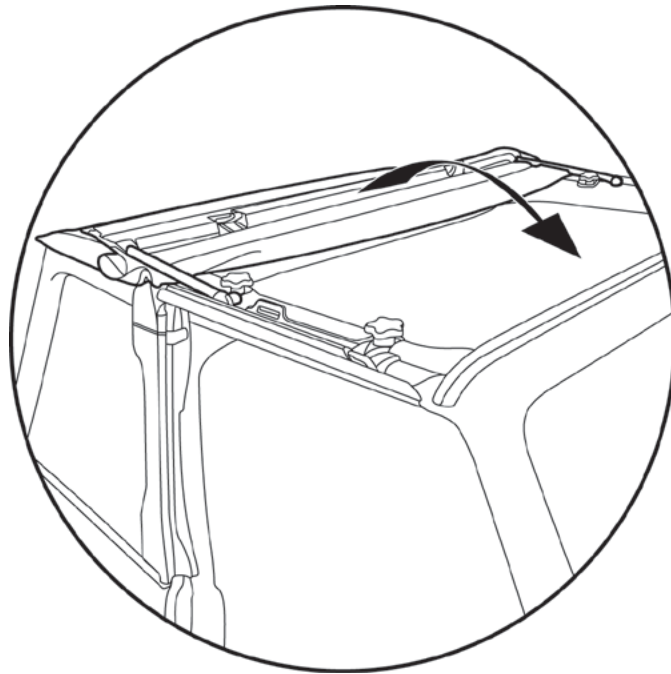

**Step 1**

Close Sunrider.

Hook the latches on the Header into the loops in the windshield and close them.



**Step 1**

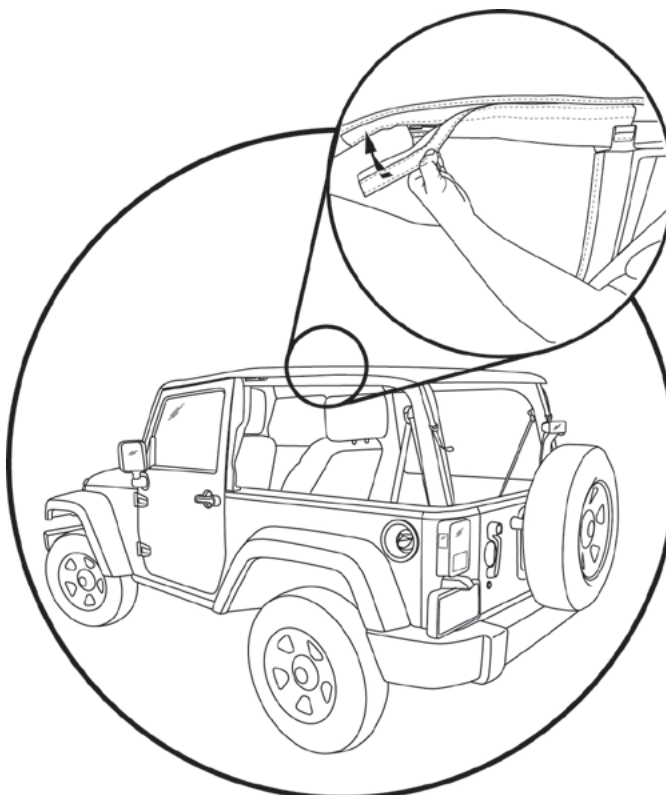

**Step 1**

Your Trektop NX can be used as a Bikini by removing the Side Windows and Rear Window and storing them carefully. Fold the protective flaps over to engage the hook and loop tape.



**WARNING**

When operating the vehicle without the Side Windows, remove the Rear Window for proper ventilation.



**AVERTISSEMENT**

Retirez la vitre arrière afin d'obtenir une bonne ventilation si les vitres de custode ne sont pas utilisées alors que le véhicule fonctionne.



**AVERTENCIA**

Cuando el vehículo funcione sin ventanas de los cuartos traseros, quite el medallón para asegurar la ventilación adecuada.



## Installation Instructions Fabric Replacement Top for Trektop NX

Vehicle Application:  
**Jeep Wrangler JK 2 Door**  
2007 – Current  
Part Number: 52822

### Care and Maintenance of your Bestop Product

Your Bestop product is made of the finest materials available. To keep it looking new and for the maximum possible wear, it will need periodic cleaning and maintenance.

**Fabric:** The fabric should be washed often using soap, warm water and a soft bristle brush. Rinse with clear water to remove all traces of soap. Bestop recommends using Bestop Cleaner (part no. 11201-00) and Bestop Protectant (part no. 11202-00). Bestop Cleaner and Bestop protectant are specially formulated to provide a total cleaning and protection system. Bestop Cleaner safely removes the toughest stains, will not harm vehicle finishes, is biodegradable and environmentally friendly. Bestop Protectant protects against UV-fading, cracking and hardening, and repels dust, grease, dirt and mildew.

**Windows:** Keep windows clean to avoid scratching. DO NOT use a brush on the windows! Wash with a water-soaked cloth or sponge and a mild dishwashing detergent. Bestop recommends Bestop Vinyl Window Cleaner (part no. 11203-00), which safely cleans and protects vinyl windows and helps prevent UV damage. NEVER WIPE THE WINDOWS WHEN THEY ARE DRY. Be careful when cleaning snow or frost from the vinyl windows since they are easily scratched and may crack at low temperatures. DO NOT roll the sides or rear window in cold weather. The windows become stiff and will crack. Cracks caused by misuse in cold temperatures are not covered under warranty.

**Zippers:** Keeping zippers cleaned and lubricated with Bestop's Zipper Cleaner (part no. 11206-00) will help prevent damage and keep the zippers in smooth working condition. If a zipper opens behind the slider, the slider may have been spread apart. This problem can usually be repaired by using an ordinary pair of pliers to bring the sides back into parallel. Return slider to the end of the zipper in the normal Open position. Squeeze lightly at first and test the zipper. If the zipper continues to remain open squeeze more firmly with the pliers and try the zipper again. Repeat this procedure until the zipper operates correctly.

**Water:** Seeping through at the seams may be stopped by applying 3-M Scotchgard® on the inside of the seams. Rips in the fabric may be repaired with Bondex® iron on patches. Iron the patches to the Inside of the top, carefully following the Bondex® instructions.

**Snaps:** Keep snaps cleaned and lubricated with silicone to help prevent snaps from sticking to the studs. If a snap does become stuck to a stud, use a screwdriver and GENTLY pry apart to prevent permanent damage to the snap or the top fabric.

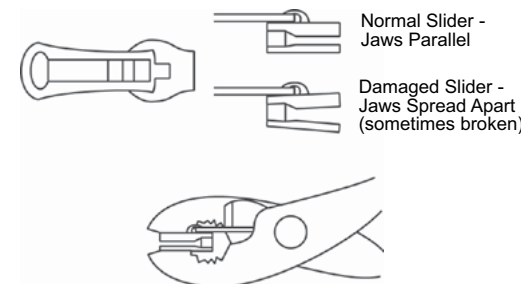

### LIMITED WARRANTY

We warrant our product to be free from defects in material and workmanship, for the terms specified below, provided there has been normal use and proper maintenance. This warranty applies to the original purchaser only. All remedies under this warranty are limited to the repair or replacement of any item or items found by the factory to be defective within the time period specified. If you have a warranty claim, first you must call our factory at the number below for instructions. You must retain proof of purchase and submit a copy with any items returned for warranty work. Upon completion of warranty work, if any, we will return the repaired or replaced item or items to you freight prepaid. Damage to our products caused by accidents, fire, vandalism, negligence, misinstallation, misuse, Acts of God, or by defective parts not manufactured by us, is not covered under this warranty.

THE WARRANTY TIME PERIOD IS AS FOLLOWS FOR REPLACE-A-TOP™, SAILCLOTH REPLACE-A-TOP™, SUPERTOP®, SUPERTOP® REPLACEMENT SKINS, SUNRIDER®, AND TIGERTOP®: TWO YEARS FROM DATE OF PURCHASE.

THE WARRANTY TIME PERIOD IS AS FOLLOWS FOR ALL OTHER "SOFT GOODS" MANUFACTURED BY OUR COMPANY (USING PRIMARILY VINYL, PLASTICS, AND/OR FOAM): ONE YEAR FROM DATE OF PURCHASE.

THE WARRANTY TIME PERIOD IS AS FOLLOWS FOR ALL OTHER "HARD GOODS" MANUFACTURED BY OUR COMPANY (USING PRIMARILY METALS, PLASTICS, AND/OR FIBERGLASS): ONE YEAR FROM DATE OF PURCHASE.

ANY IMPLIED WARRANTIES OF MERCHANTABILITY AND/OR FITNESS FOR A PARTICULAR PURPOSE CREATED HEREBY ARE LIMITED IN DURATION TO THE SAME DURATION AND SCOPE AS THE EXPRESS WRITTEN WARRANTY. OUR COMPANY SHALL NOT BE LIABLE FOR ANY INCIDENTAL OR CONSEQUENTIAL DAMAGE.

Some states do not allow limitations on how long an implied warranty lasts, or the exclusion or limitation of incidental or consequential damages, so the above limitations or exclusions may not apply to you. This warranty gives you specific legal rights, and you may also have other rights which vary from state to state.

For further information or request for warranty work, please contact:

Bestop Inc., Customer Service  
Toll-Free: (800) 845-3567  
Main: (303) 465-1755  
E-mail: [csbestop@Bestop.com](mailto:csbestop@Bestop.com)  
Website: [www.Bestop.com](http://www.Bestop.com)



## Installation Instructions Fabric Replacement Top for Trektop NX

Vehicle Application:  
**Jeep Wrangler JK 2 Door**  
2007 – Current  
Part Number: 52822

### Cuidado y mantenimiento de su producto Bestop

Su producto Bestop está hecho con materiales de la más alta calidad. Para mantener su apariencia nueva y alargar su uso al máximo posible, necesitará limpieza y mantenimiento periódicos.

**Tela:** debe lavar la tela con frecuencia usando jabón, agua tibia y un cepillo de cerdas suaves. Enjuague con agua limpia para eliminar todos los residuos de jabón. Bestop recomienda utilizar el Limpiador Bestop (número de parte 11201-00) y el Protector Bestop (número de parte 11202-00). El limpiador y el protector Bestop están formulados especialmente para ofrecer un sistema de limpieza y protección total. El limpiador Bestop quita las manchas más difíciles, no daña los acabados del vehículo, es biodegradable y no daña el medio ambiente. El protector Bestop protege contra la decoloración que causan los rayos UV y contra el agrietamiento y endurecimiento; además, repele el polvo, grasa, suciedad y moho.

**Cremalleras:** conserve las cremalleras limpias y lubricadas con el limpiador de cremalleras Bestop (número de parte 11206-00), que ayuda a prevenir daños y mantiene las cremalleras en óptimas condiciones de funcionamiento. Si la cremallera se abre detrás de la corredera, es posible que las mordazas de la corredera se hayan separado. Por lo general, este problema se repara fácilmente con unas pinzas comunes para volver a poner los lados en paralelo. Regrese la corredera al extremo de la cremallera en la posición abierta normal. Apriete un poco al principio y pruebe la cremallera. Si la cremallera sigue abierta, apriete con mayor firmeza con las pinzas y vuelva a probar la cremallera. Repita este procedimiento hasta que la cremallera funcione correctamente.

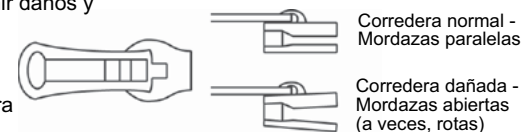

**Agua:** para eliminar la filtración de agua a través de las costuras, aplique cinta Scotchgard® de 3-M en la parte interior de las costuras. Los desgarres de la tela pueden repararse con parches Bondex® para aplicar con plancha. Plancha los parches en el interior del toldo, siguiendo con cuidado las instrucciones de Bondex®.

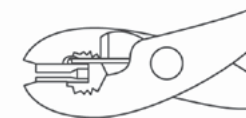

**Broches:** conserve los broches limpios y lubricados con silicona para evitar que se peguen a los corchetes de encaje. Si se quedan pegados a un corchete, use un destornillador y CON CUIDADO separe las dos piezas para evitar daño permanente al broche o a la tela del toldo.

### GARANTÍA LIMITADA

Garantizamos que nuestro producto estará exento de defectos en materiales y mano de obra durante los plazos que se indican a continuación, siempre que se les dé el uso normal y el mantenimiento adecuado. Esta garantía aplica únicamente al comprador original. Todos los recursos previstos en esta garantía se limitan a la reparación o sustitución de cualquier artículo o artículos que la fábrica determine que efectivamente presentan defectos dentro del período especificado. Si desea presentar una reclamación de garantía, primero debe llamar a nuestra fábrica al número que se indica a continuación para recibir instrucciones. Debe conservar el comprobante de compra y enviar una copia junto con los artículos devueltos para la reparación de garantía. Al término del trabajo de garantía, si lo hubo, devolveremos el o los artículos reparados o sustituidos a su domicilio por flete prepago por usted. Esta garantía no cubre los daños que sufran nuestros productos a causa de accidentes, incendio, vandalismo, negligencia, errores de instalación, mal uso, causas de fuerza mayor o provocados por partes defectuosas que no fabricamos nosotros.

EL PERÍODO DE GARANTÍA DE REPLACE-A-TOP™, SAILCLOTH REPLACE-A-TOP™, SUPERTOP®, SUPERTOP® REPLACEMENT SKINS, SUNRIDER® Y TIGERTOP® ES EL SIGUIENTE: DOS AÑOS A PARTIR DE LA FECHA DE COMPRA.

EL PERÍODO DE GARANTÍA PARA TODOS LOS DEMÁS “PRODUCTOS BLANDOS” FABRICADOS POR NUESTRA EMPRESA (EN CUYA FABRICACIÓN SE UTILIZARON SOBRE TODO VINILOS, PLÁSTICOS O ESPUMA) ES EL SIGUIENTE: UN AÑO A PARTIR DE LA FECHA DE COMPRA.

EL PERÍODO DE GARANTÍA PARA TODOS LOS DEMÁS “PRODUCTOS RÍGIDOS” FABRICADOS POR NUESTRA EMPRESA (EN CUYA FABRICACIÓN SE UTILIZARON SOBRE TODO METALES, PLÁSTICOS O FIBRA DE VIDRIO) ES EL SIGUIENTE: UN AÑO A PARTIR DE LA FECHA DE COMPRA.

TODAS LAS GARANTÍAS IMPLÍCITAS DE COMERCIABILIDAD O IDONEIDAD PARA UN FIN ESPECÍFICO QUE AQUÍ SE CREAN SE LIMITAN EXACTAMENTE A LA MISMA DURACIÓN Y ALCANCE QUE LA GARANTÍA EXPLÍCITA ESCRITA. NUESTRA COMPAÑÍA NO SERÁ RESPONSABLE POR NINGÚN DAÑO INCIDENTAL O EMERGENTE.

En algunos estados no se permiten las limitaciones respecto a la duración de las garantías implícitas ni la exclusión o limitación de los daños incidentales o emergentes, por lo que es posible que las anteriores limitaciones o exclusiones no apliquen a usted. Esta garantía le confiere derechos legales específicos, y también puede tener otros derechos, los cuales varían de un estado a otro.

Para obtener más información o solicitar un trabajo de garantía, comuníquese con:

Atención a clientes de Bestop Inc  
Número para llamar sin costo: (800)845-3567  
Conmutador: (303)465-1755  
Courriel : csbestop@Bestop.com  
Sitio web: www.Bestop.com



## Installation Instructions Fabric Replacement Top for Trektop NX

Vehicle Application:  
**Jeep Wrangler JK 2 Door**  
2007 – Current  
Part Number: 52822

### Soin et entretien de votre produit Bestop

Votre produit Bestop est fabriqué des meilleurs matériaux disponibles. Il devra être nettoyé et entretenu régulièrement afin de maintenir son apparence neuve et pour une durée d'utilisation maximale.

**Tissu :** Le tissu doit être lavé régulièrement à l'aide de savon, d'eau chaude et d'une brosse à soies douces. Rincer à l'eau claire afin d'éliminer toute trace de savon. Bestop recommande d'utiliser le nettoyant Bestop Cleaner (no de pièce 11201-00) et le protecteur Bestop Protectant (no de pièce 11202-00). Le nettoyant Bestop Cleaner et le protecteur Bestop Protectant sont spécialement formulés pour fournir un système de nettoyage et de protection complet. Le nettoyant Bestop Cleaner élimine de manière sécuritaire les taches les plus tenaces, n'endommagera pas les finis du véhicule, est biodégradable et respectueux de l'environnement. Le protecteur Bestop Protectant prévient la décoloration, la fissuration et le durcissement causés par les UV, et repousse la poussière, la graisse, la saleté et les moisissures.

**Fermetures à glissière :** Maintenir les fermetures à glissière propres et lubrifiées à l'aide du nettoyant Zipper Cleaner (no de pièce 11206-00) de Bestop aidera à protéger des dommages et maintiendra les fermetures à glissière en bon état de fonctionnement. Si une fermeture à glissière ouvre derrière la glissière, la glissière peut avoir été forcée au point de s'ouvrir. Le problème peut habituellement être réparé en utilisant des pinces ordinaires pour remettre les côtés parallèles. Remettre la glissière au bout de la fermeture à glissière, dans la position Ouverte normale. Serrer légèrement au début et vérifier le fonctionnement de la fermeture à glissière. Si la fermeture à glissière continue de rester ouverte, serrer plus fortement à l'aide des pinces et essayer la fermeture à glissière de nouveau. Répéter le processus jusqu'à ce que la fermeture à glissière fonctionne correctement.

**Eau :** Les infiltrations d'eau aux coutures peuvent être arrêtées par l'application de ScotchgardMD 3M sur l'intérieur des coutures. Les déchirures dans le tissu peuvent être réparées grâce aux pièces thermocollantes BondexMD. Fixer les pièces thermocollantes à l'aide d'un fer à repasser sur l'intérieur du toit, en suivant soigneusement les instructions de BondexMD.

**Boutons pression :** Maintenir les boutons pression propres à l'aide de silicone pour empêcher les boutons pression de coller aux rivets. Si un bouton pression reste collé à un rivet, utiliser un tournevis et appliquer une FAIBLE PRESSION afin d'éviter d'endommager le bouton pression ou le tissu du toit.

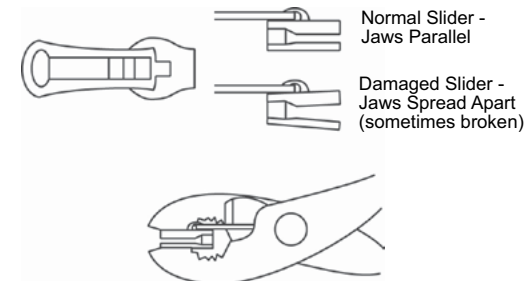

### GARANTIE LIMITÉE

Nous garantissons que notre produit est exempt de défauts de matériaux et de fabrication, pour les modalités précisées ci-dessous, pourvu qu'il ait été utilisé de façon normale et entretenu de manière adéquate. Cette garantie s'applique à l'acheteur original seulement. Tous les recours sous cette garantie sont limités à la réparation ou au remplacement de tout article ou articles reconnus par l'usine comme étant défectueux pendant la période de temps spécifiée. Si vous devez faire une réclamation, vous devez d'abord appeler notre usine au numéro ci-dessous pour obtenir des instructions. Vous devez conserver la preuve d'achat et en transmettre une copie avec tous les articles retournés pour réparation sous garantie. À la fin des travaux de garantie, le cas échéant, nous vous retournerons l'article ou les articles réparés ou remplacés en port payé à l'avance. Les dommages à nos produits causés par les accidents, les incendies, le vandalisme, la négligence, une mauvaise utilisation, une mauvaise installation, les cas fortuits ou par des pièces défectueuses qui ne sont pas fabriqués par nous, ne sont pas couverts par cette garantie..

LA PÉRIODE DE GARANTIE EST COMME SUIVANT POUR REPLACE-A-TOPMC, SAILCLOTH REPLACE-A-TOPMC, SUPERTOPMD, LES PEAUX DE RECHANGE SUPERTOPMD, SUNRIDERMMD ET TIGERTOPMD : DEUX ANS À COMPTER DE LA DATE D'ACHAT.

LA PÉRIODE DE GARANTIE EST COMME SUIVANT POUR TOUS LES AUTRES "BIENS DE CONSOMMATION NON DURABLES" FABRIQUÉS PAR NOTRE SOCIÉTÉ (EN UTILISANT PRINCIPALEMENT DES VINYLES, DES MATIÈRES PLASTIQUES ET/OU DE LA MOUSSE): UN AN À COMPTER DE LA DATE D'ACHAT.

LA PÉRIODE DE GARANTIE EST COMME SUIVANT POUR TOUS LES AUTRES "BIENS DE CONSOMMATION DURABLES" FABRIQUÉS PAR NOTRE SOCIÉTÉ (EN UTILISANT PRINCIPALEMENT DES MÉTAUX, DES MATIÈRES PLASTIQUES ET/OU DE LA FIBRE DE VERRE): UN AN À COMPTER DE LA DATE D'ACHAT.

TOUTE GARANTIE IMPLICITE DE QUALITÉ MARCHANDE ET/OU D'ADÉQUATION À UN USAGE PARTICULIER CRÉÉ PAR LES PRÉSENTES EST LIMITÉE AUX MÊMES CONDITIONS ET AU MÊME CHAMP D'APPLICATION QUE LA GARANTIE EXPRESSE ÉCRITE. NOTRE SOCIÉTÉ NE SERA PAS TENUE POUR RESPONSABLE POUR TOUT DOMMAGE ACCESSOIRE OU INDIRECT

Certaines provinces et certains territoires n'autorisent pas les limitations sur la durée d'une garantie implicite, ou l'exclusion ou la limitation des dommages accessoires ou indirects, et il se pourrait donc que les limitations ou exclusions susmentionnées ne s'appliquent pas à vous. Cette garantie vous donne des droits légaux spécifiques, et vous pouvez également avoir d'autres droits qui varient d'une province à l'autre et d'un territoire à l'autre.

Pour de plus amples renseignements et demander une réparation, communiquer avec:

Le service à la clientèle Bestop Inc.

Sans frais : (800)845-3567

Local: (303)465-1755

Courriel: csbestop@Bestop.com

Site Web: www.Bestop.com