

**Jeep® A-Pillar Switch Pod (Left or Right Side - 2011 to present JK)**

**HARDWARE NOTE:** Switch Pod has been designed to reuse factory metal retainer clips located on the back of factory trim and rear tailgate wire cover. **DO NOT DISCARD** clip removed from factory A-pillar trim.

Item List:  
(1) A-Pillar Switch Pod



**NOTE:** Switches are sold separately  
Switch Part Numbers  
17235.01 - Amber  
17235.02 - Red  
17235.03 - Blue  
17235.04 - Green

**Important! Please read instructions completely before installing Switch Pod.**

**Step 1.** Using T20 Torx head screw driver remove sun visor mounting screws (pic.1). Remove side plastic Phillips head retainer clip from upper side windshield trim (Pic.2). **DO NOT DISCARD.** Clip will be reused.



pic.1



pic.2

**Step 2.** Remove upper trim from windshield frame (Pic.3). Trim is held in place by a barbed white retainer clip. **DO NOT DISCARD OR BREAK.** Clip will be reused.



pic.3



pic.4

**Step 3.** Pop lower A-pillar trim from windshield frame (pic.4). Using a small flat head screw driver remove metal retainer clip from factory trim panel (Pic.5).

**Step 4.** A second metal retainer clip will be needed for new A-Pillar Pod. Open rear tailgate and remove plastic rear wire cover plate (pic.6). Remove center clip using a flat head screw driver (pic.7). Reinstall rear cover.

**Step 5.** Reinstall metal retainer clips onto new A-Pillar Switch Pod (Pic.8). Make sure clip is aligned with plastic tabs before pressing into place.



pic.5



pic.6

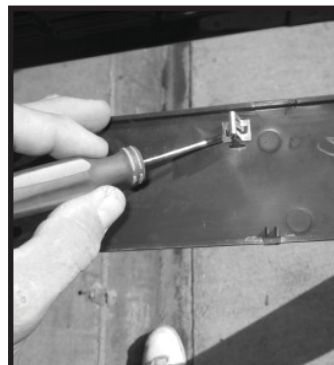

pic.7



pic.8

**Jeep® A-Pillar Switch Pod (Left or Right Side - 2011- present JK)****Important! Please read instructions completely before installing Switch Pod.**

Step 5. Cut openings for switches.

**NOTE: Switch pods have been designed to match original trim thickness. Care must be taken while cutting switch openings.**

Score cut lines before cutting through plastic. Score inbound of outer edge towards center block. This will insure opening is not cut too large for switch housing (pic.7).



pic.7



pic.8

Step 7. Run box knife over cut lines several times before pressing blade through plastic.

**CAUTION: ALWAYS CUT AWAY FROM BODY.**

If needed the cutting blade can be heated to aid in cutting plastic (pic.8).



pic.9



pic.10

Step 8. Insert switch into cut opening. Trim opening as needed. Only remove enough material to allow switch to be installed. If too much material is removed switch will be loose and result in a poor fit (pic. 9 & 10).

Step 9. Place new switch pod to windshield frame making sure to align lower metal retainer clip first (pic.11). With lower clip slightly inserted into frame align upper clip and alignment peg into frame (pic.12). Snap switch pod into place.



pic.11



pic.12

Step10. Check fitment of new switch pod. Trim should fit just to the outside and inside edge of the windshield frame. Reinstall upper windshield trim (reversal of steps #1 - 2). Inspect fitment with upper trim in place. Open and close door. If Pod moves reposition pod to frame until movement has stopped.

Rocker Switch, Two Position, Black with Indicator Light, Rugged Ridge, Universal Application



1. Wiring for +12v output.

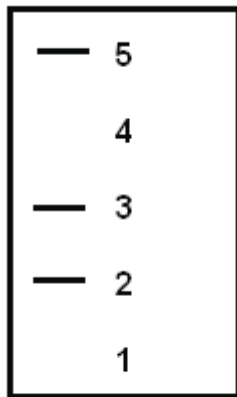

(A5) - Ground input (Connect to chassis ground)

(A3) + 12v input (Connect to +12v switched or constant power source)

(A2) + 12v output (Output to +12v accessory)

A B

2. Wiring when used with Rugged Ridge Fog Lights.

- A. Connect black wire (85) from relay directly to ground.
- B. Cut black wire on relay (86).
- C. Connect black wire (86) to (A2) on switch.

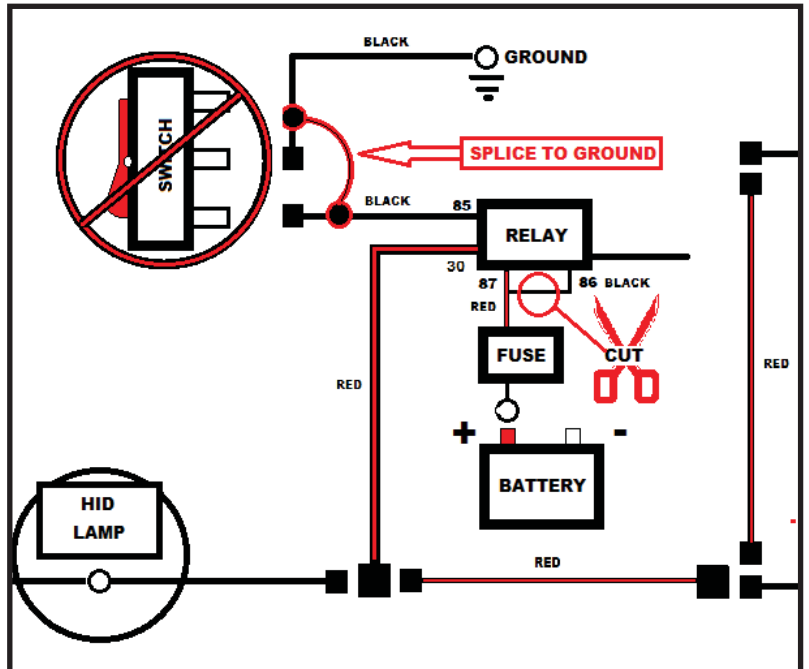

For Technical Assistance Contact:  
 OMIX-ADA Tech Support  
 Phone: 1-800-449-6649  
 Email: techsupport@omix-ada.com  
 Web: www.Omix-Ada.com