



PART NUMBER: 11596.04  
PRODUCT: Nerf step  
APPLICATION: 18-Jeep JL 4 Door

460 HORIZON DR. | SUWANEE, GA 30024 | PHONE: 770-614-6101 | FAX: 770-614-6069 | www.omix-ada.com



HARDWARE DESCRIPTION	QTY.
KIT# HWK-00010X	
M8x30mm flanged hex bolt with washer	6
M8x25mm Flanged hex head bolt ( Black zinc)	12
M8 flanged nuts	12

**Step 1.** Identify the driver side step.

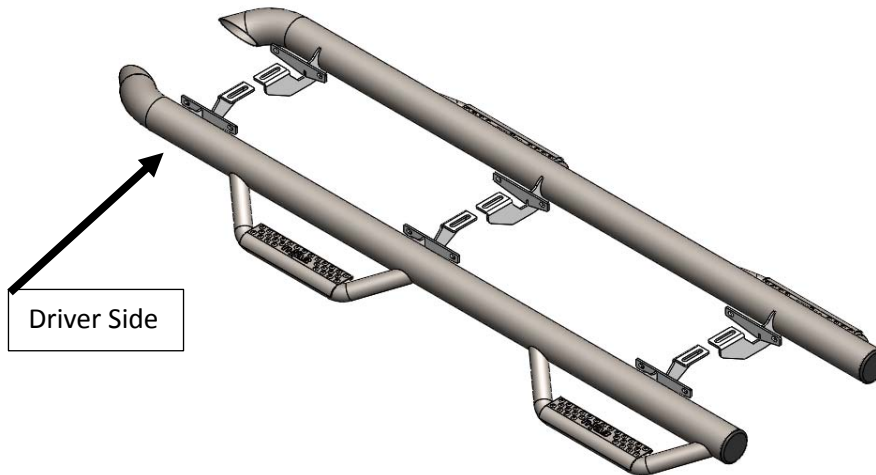

OMIX-ADA® TECHNICAL SUPPORT

PHONE: M-F 8am - 5pm EST 1-800-449-6649 | TICKET: webmaster@omixsupport.com

**Step 2.** Remove the factory running boards and discard.



**Step 3.** Starting with driver side step; carefully raise up into position and align the brackets with the factory mounting points with the horizontal part of the bracket on the outside of the pinch weld.

**Step 4.** Next, start one of the supplied M8x30mm hex head flanged bolt and washer starting with the center bracket in the factory threaded hole and leave loose.

**Step 5.** Start two M8x25mm black zinc flanged bolts and two M8 flanged nuts in the pinch weld and leave loose for final adjustment.



**Step 6.** Continue installing the rest of the hardware in the remaining brackets and leave loose.

**Step 7.** Adjust the nerf-step where the main bar is level with the body of the vehicle.

**Step 8.** First, tighten all the hardware that attaches the bracket to the pinch weld of the vehicle.



**Step 9.** Next, tighten the remaining hardware that attaches the bracket to the upper body mount.



**Step 10.** Repeat steps 4-9 for the Driver side.